

**TECHNICAL MANUAL**

**GENERAL SUPPORT**

**MAINTENANCE MANUAL**

**CONVERTER, DIRECT CURRENT**

**CV-3734/T**

**(NSN 5805-01-130-1499)**





**5**

SAFETY STEPS TO FOLLOW IF SOMEONE IS THE VICTIM OF ELECTRICAL SHOCK

**1**

DO NOT TRY TO PULL OR GRAB THE INDIVIDUAL

**2**

IF POSSIBLE, TURN OFF THE ELECTRICAL POWER

**3**

IF YOU CANNOT TURN OFF THE ELECTRICAL POWER, PULL, PUSH, OR LIFT THE PERSON TO SAFETY USING A WOODEN POLE OR A ROPE OR SOME OTHER INSULATING MATERIAL

**4**

SEND FOR HELP AS SOON AS POSSIBLE

**5**

AFTER THE INJURED PERSON IS FREE OF CONTACT WITH THE SOURCE OF ELECTRICAL SHOCK, MOVE THE PERSON A SHORT DISTANCE AWAY AND IMMEDIATELY START ARTIFICIAL RESUSCITATION

## **WARNINGS**

### **HIGH CURRENT**

Is used in the operation of this equipment

### **DEATH ON CONTACT**

may result if personnel fail to observe safety precautions.

When maintenance adjustments on this equipment are made with power applied, be careful when working near the interior of the equipment, or near the power distributing wiring.

Never work on electronic equipment unless there is another person nearby who is familiar with the operation and hazards of the equipment and who is competent in administering first aid. When the technician is aided by operators, he must warn them about dangerous areas.

Whenever possible, the power supply to the equipment must be shut off before beginning maintenance work on the equipment. Take particular care to ground every capacitor likely to hold a dangerous potential.

When working inside the equipment, after the power has been turned off, always ground every part before touching it.

Be careful not to contact high-current connections when installing or operating this equipment.

Whenever the nature of the operation permits, keep one hand away from the equipment to reduce the hazard of current flowing through vital organs of the body.

Adequate ventilation should be provided while using TRICHLOROTRIFLUOROETHANE. Prolonged breathing of vapor should be avoided. The solvent should not be used near heat or open flame; the products of decomposition are toxic and irritating. Since TRICHLOROTRIFLUOROETHANE dissolves natural oils, prolonged contact should be avoided. When necessary, use gloves which the solvent cannot penetrate. If the solvent is taken internally, consult a physician immediately.

Compressed air shall not be used for cleaning purposes except where reduced to less than 29 pounds per square inch (psi) and then only with effective chip guarding and personnel protective equipment. Do not use compressed air to dry parts when TRICHLOROTRIFLUOROETHANE has been used. Compressed air is dangerous and can cause serious bodily harm if protective means or methods are not observed to prevent chips or particles (of whatever size) from being blown into the eyes or unbroken skin of the operator or other personnel.

## **CAUTIONS**

Proper grounding is essential to satisfactory operation of the converter.

This equipment is transistorized; observe all cautions to prevent transistor damage. Do not make continuity or resistance checks other than those specified in the tests. Damage to the transistors and microelectronic devices, which can impair the performance of the equipment, may result if improper battery voltages and polarities are applied.

GENERAL SUPPORT MAINTENANCE MANUAL

CONVERTER, DIRECT CURRENT

CV-3734/T

(NSN 5805-01-130-1499)

**REPORTING ERRORS AND RECOMMENDING IMPROVEMENTS**

**You can help improve this manual. If you find any mistakes or if you know of a way to improve the procedures, please let us know. Mail your letter, DA Form 2028 (Recommended Changes to Publications and Blank Forms), or DA Form 2028-2 located in the back of this manual direct to Commander, US Army Communications-Electronics Command and Fort Monmouth, ATTN: DR-SEL-ME-MP, Fort Monmouth, NJ, 07703-5007. A reply will be furnished to you.**

TABLE OF CONTENTS

		<i>Paragraph</i>	<i>Page</i>
			iii
	HOW TO USE THIS MANUAL .....		
CHAPTER	<b>1. INTRODUCTION</b>		
Section	<b>I. General Information</b>		
	Scope .....	1-1	1-1
	Maintenance Forms, Records and Reports .....	1-2	1-1
	Destruction of Army Materiel to Prevent Enemy Use .....	1-3	1-1
	Preparation for Storage or Shipment .....	1-4	1-1
	Consolidated Index of Army Publications and Blank Forms .....	1-5	1-1
	Official Nomenclature, Names and Designations .....	1-6	1-1
	Reporting Equipment Improvement Recommendations (EIR) .....	1-7	1-1
	Warranty Information .....	1-8	1-1
	<b>II. Equipment Description</b>		
	Equipment Characteristics, Capabilities, and Features .....	1-9	1-2
	Location and Description of Major Components .....	1-10	1-2
	Equipment Data .....	1-11	1-2
	Safety, Care and Handling .....	1-12	1-2
Section	<b>III. Technical Principles of Operation Block Diagram Description</b>	1-13	1-2
	Circuit Analysis .....	1-14	1-4
CHAPTER	<b>2. GENERAL SUPPORT MAINTENANCE INSTRUCTIONS</b>		
Section	<b>I. Repair Parts, Tools, TMDE, and Support Equipment</b>		
	Common Tools and Equipment .....	2-1	2-1
	Special Tools, TMDE, and Support Equipment .....	2-2	2-1
	Repair Parts .....	2-3	2-1
	<b>II. Troubleshooting</b>		
	General Troubleshooting Information .....	2-4	2-1
	Troubleshooting Table .....	2-5	2-1
	<b>III. Maintenance Procedures</b>		
	Maintenance Functions .....	2-6	2-19
	Preliminary Maintenance Procedures .....	2-7	2-19
	Cleaning .....	2-8	2-19

TABLE OF CONTENTS-Continued

	<i>Paragraph</i>	<i>Page</i>
	Removal and Replacement .....	2 - 9 2 - 20
	Disassembly and Reassembly .....	2 - 10 2 - 23
	Printed Circuit Board Repair .....	2 - 11 2 - 29
	Painting .....	2 - 12 2 - 30
<b>Section</b>	<b>IV. Test Procedures</b>	
	General .....	2 - 13 2 - 30
	Physical Test and Inspections .....	2 - 14 2 - 30
<b>APPENDIX</b>	<b>A. REFERENCES .....</b>	<b>A - 1</b>
	<b>B. EXPENDABLE SUPPLIES AND MATERIALS LIST .....</b>	<b>B - 1</b>
	<b>C. ILLUSTRATED LIST OF MANUFACTURED ITEMS .....</b>	<b>C - 1</b>

LIST OF ILLUSTRATIONS

<i>Number</i>	<i>Title</i>	<i>Page</i>
1 - 1	Converter, Direct Current CV-3734/T .....	1 - 0
1 - 2	Simplified Block Diagram .....	1 - 3
1 - 3	EMI Filter and Related Components and 20 kHz Switching Converter .....	1 - 5
1 - 4	Output Power Section .....	1 - 8
1 - 5	Regulator Loop .....	1 - 10
1 - 6	Undervoltage and Overvoltage Protection Circuits .....	1 - 12
1 - 7	Primary Control Circuits .....	1 - 14
1 - 8	Drive Circuits .....	1 - 16
1 - 9	Soft Start, Overvoltage and Current Limit Circuits .....	1 - 18
2 - 1	Operational Test Setup .....	2 - 2
2 - 2	Bench Test Setup .....	2 - 4
2 - 3	Troubleshooting Setup #1 .....	2 - 7
2 - 4	① Heatsink Parts Location (Sheet 1 of 2) .....	2 - 9
2 - 4	② Heatsink Parts Location (Sheet 2 of 2) .....	2 - 10
2 - 5	20 kHz Converter and Output Power Waveforms .....	2 - 11
2 - 6	A2 PCB Parts Location .....	2 - 12
2 - 7	A1 PCB Parts Location .....	2 - 14
2 - 8	① A1 PCB Waveforms (Sheet 1 of 2) .....	2 - 15
2 - 8	② A1 PCB Waveforms (Sheet 2 of 2) .....	2 - 16
2 - 9	Troubleshooting Setup #2 .....	2 - 18
2 - 10	Converter CV-3734/T, Exploded View .....	2 - 21
2 - 11	① Front Panel Disassembly (Sheet 1 of 2) .....	2 - 24
2 - 11	② Front Panel Disassembly (Sheet 2 of 2) .....	2 - 25
2 - 12	Rear Panel Disassembly .....	2 - 26
C - 1	Test Cable Fabrication Details .....	C - 2
C - 2	Jumper Cable Fabrication Details .....	C - 3
FO - 1	Color Code Marking for MIL-STD Resistors, Inductors, and Capacitors .....	In back
FO - 2	① Converter Assembly Schematic Diagram (Sheet 1 of 4) .....	of manual
FO - 2	② Converter Assembly Schematic Diagram (Sheet 2 of 4) .....	
FO - 2	③ Converter Assembly Schematic Diagram (Sheet 3 of 4) .....	
FO - 2	④ Converter Assembly Schematic Diagram (Sheet 4 of 4) .....	

## HOW TO USE THIS MANUAL

### *Location of Subjects in Manual*

In this manual, paragraphs are numbered sequentially. If you are looking for specific information, use the table of contents in the front of this manual to locate the paragraph and page where a topic is discussed.

Refer to Appendix A, REFERENCES, for the complete title of all forms, technical bulletins, technical manuals and military specifications referenced in this manual.

Refer to TM 11-6130-429-20P for organizational maintenance parts and special tools lists (RPSTL); refer to TM 11-6130-429-40P for general support maintenance repair parts and special tools lists (RPSTL) used with this manual.

### *Use of Manual for Task Performance.*

You must familiarize yourself with the entire maintenance procedure before beginning the maintenance task.

You should also familiarize yourself with the operational capabilities of the converter in order to properly perform your maintenance tasks. Refer to the operator's manual TM 11-6130-429-12 for this information.

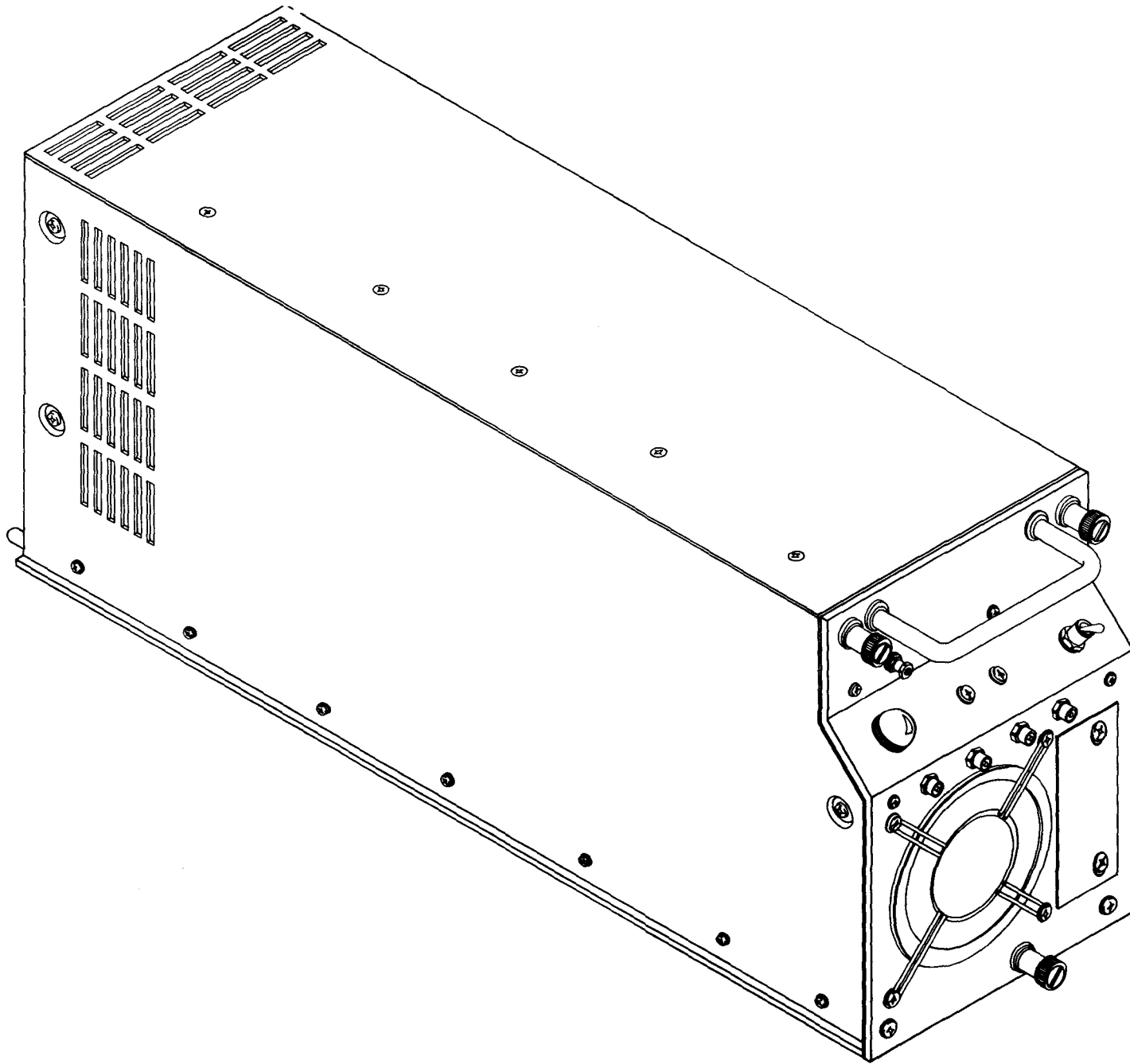

Figure 1-1. Converter, Direct Current CV-3734T.

EL9AW001



# CHAPTER 1

## INTRODUCTION

### SECTION I. GENERAL INFORMATION

#### 1-1. Scope

Type of Manual: General Support

Model Number and Equipment Name: Converter, Direct Current CV-3734/T Purpose of Equipment: Furnishes regulated dc voltage to equipment in AN/TTC-38(V) and AN/TYC-39(V) mobile, central office telephone switching systems.

#### 1-2. Maintenance Forms, Records, and Reports

*a. Reports of Maintenance and Unsatisfactory Equipment.* Department of the Army forms and procedures used for equipment maintenance will be those prescribed by DA Pam 738-750 as contained in Maintenance Management Update.

*b. Report of Packaging and Handling Deficiencies.* Fill out and forward SF 364 (Report of Discrepancy (ROD) as prescribed in AR 735-11-2/DLAR 4140.55/NAVMATINST 4355.73A/AFR 400-54/MCO 4430.3F.

*c. Discrepancy in Shipment Report (DISREP) (SF 361).* Fill out and forward Discrepancy in Shipment Report (DISREP) (SF311) as prescribed in AR 55-38/NAVSUPINST 4610.33C/AFR 75-18/MCO P4610.19D/DLAR 4500.15.

#### 1-3. Destruction of Army Materiel to Prevent Enemy Use

Destruction of Army materiel to prevent enemy use is described in TM 750-244-2.

#### 1-4. Preparation for Storage or Shipment

Preparation for storage or shipment will be performed in accordance with TM 740-90-1.

#### 1-5. Consolidated Index of Army Publications and Blank Forms

Refer to the latest issue of DA Pam 310-1 to determine whether there are new editions, changes, or additional publications pertaining to the equipment.

#### 1-6. Official Nomenclature, Names, and Designations

Official nomenclature must be used when filling out

report forms or looking up technical manuals.

<i>Common Name</i>	<i>Official Nomenclature</i>
Baseplate	Assembly, Baseplate
Converter	Converter, Direct Current CV-3734/T
Front Panel	Assembly, Front Panel
Heatsink	Assembly, Heatsink
A 1	Printed Circuit Board-A1
A 2	Printed Circuit Board-A2
Rear Panel	Assembly, Rear Panel

#### 1-7. Reporting Equipment Improvement Recommendations (EIR)

If your converter needs improvement, let us know. Send us an EIR. You, the user, are the only one who can tell us what you don't like about your equipment. Let us know why you don't like the design. Put it on an SF 368 (Quality Deficiency Report). Mail it to Commander, US Army Communications-Electronics Command and Fort Monmouth, ATTN: DR-SEL-ME-MP, Fort Monmouth, New Jersey 07703-5007. We'll send you a reply.

#### 1-8. Warranty Information

Converter CV-3734/T is warranted by Transistor Devices Inc. for 90 days from date of delivery to the Government. It starts on the date found in block 23 DA Form 2408-9, in the logbook. Report all defects in materials or workmanship to your supervisor, who will take appropriate action through your organizational maintenance shop. This warranty does not apply to the converter or any of its components if:

*a.* The item has been repaired, worked upon, disassembled, or altered by persons not authorized by the Army in such a manner as to injure the stability or reliability of the item.

*b.* The item has been subjected to misuse, negligence, or accident.

*c.* The item has not been connected, installed, used, or adjusted in accordance with the procedures of this manual, the serial number of the item has been altered, defaced, or removed.

*d.* Problem is caused by normal wear and tear from usage.

## SECTION II. EQUIPMENT DESCRIPTION

### 1-9. Equipment Characteristics, Capabilities, and Features

*a.* Purpose of Converter:

- Supplies regulated DC voltage to equipment used in AN/TTC-38(V) and AN/TYC-39(V) telephone switching systems.

*b.* Capabilities and Features:

- External shutdown capability, from equipment or control panel converter supplies.
- Automatic shutdown in the event of overload or underload conditions.
- Emergency voltage adjustment.
- Test points for monitoring output circuits.

### 1-10. Location and Description of Major Components

All major components of the converter are located on the front and rear panels, and inside the main chassis assembly.

### 1-11. Equipment Data

Weight and Dimensions:

Rack Mounted:

Weight 11.350 Kg (25 lbs. approximate)

Length	44.45 cm (17.50 in.)
Width	12.4 cm (4.88 in.)
Height	17.78 cm (7.0 in.)
Environmental Conditions:	
Ambient temperature	-70° F (-57°C) to +125°F (+52°C)
Relative Humidity	98%
Altitude	Up to 25,000 feet (7,500 meters) above sea level
Technical characteristics	
Output voltages	+5V direct current
Output current	+75 amperes
Nominal power	375 watts
Operating power requirements	21-30 volts direct current
Regulation-Peak-to-Peak	0 to 10% ± of full load
Ripple and Noise	10% to full load ±2%

### 1-12. Safety, Care and Handling

Observe all WARNINGS, CAUTIONS, and NOTES in this manual. This equipment can be extremely dangerous if these instructions are not followed.

## SECTION III. TECHNICAL PRINCIPLES OF OPERATION

### 1-13. Block Diagram Description

(fig. 1-2)

*a.* Two connectors (P1 and P2) are provided for dual input and output connections. The outputs are interconnected to the loads through isolation diodes which enable two or more converters to be used in redundancy. If one converter fails, the standby converter will automatically take over without voltage interruption (glitching) at the load. Two converters may be used to supply a single load or three converters may be used to supply two independent loads. In this case, the third converter stands by and will take over if either of the two converters fail. Input voltage may vary between 21 and 30V with transients.

*b.* The converter contains a 20 kHz pulse width modulated DC-DC converter with transformer isola-

tion between input and output. The output voltage is monitored by the control circuits which, in turn, adjust the pulse width (duty cycle) of the 20 kHz switching regulator automatically so that the output voltage is maintained independent of the input line or output load conditions.

*c.* The input EMI filter prevents electromagnetic interferences generated in the switching converter from reaching the input DC line and similarly prevents electromagnetic interference on the DC line from reaching the regulated output voltage. The unit is also protected against damage if a reverse input voltage is applied by a large reverse rectifier directly across the bus. The capacity of this rectifier is sufficient to trip the system circuit breaker without damage to the converter.

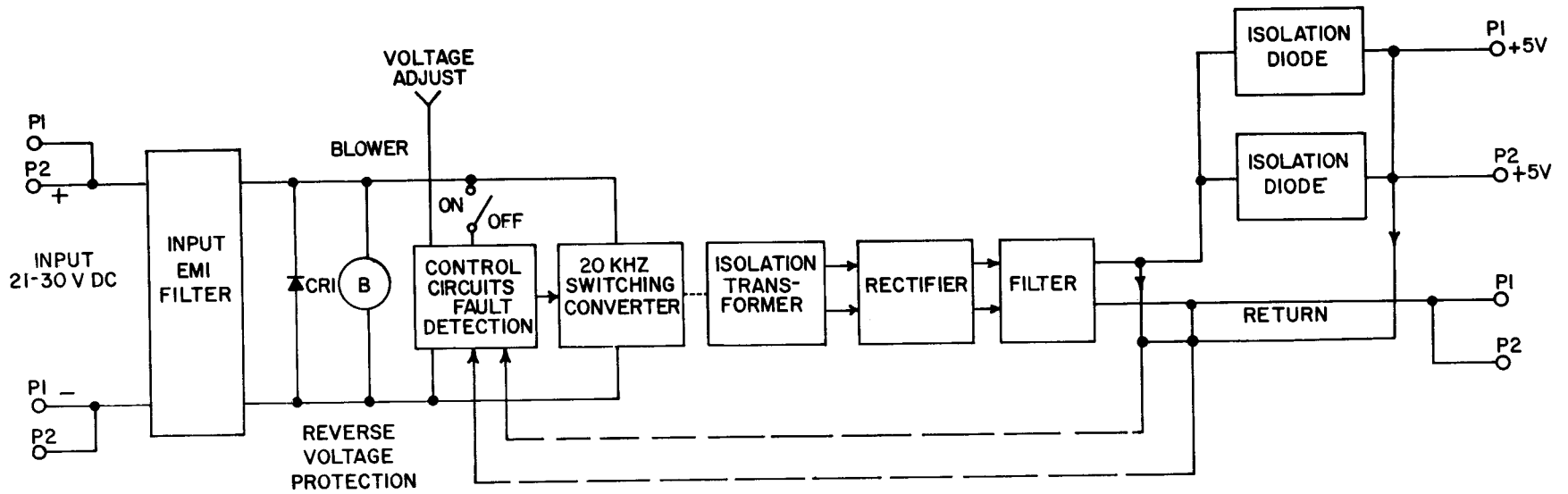

**EL9AW002**

*Figure 1-2. Simplified Block Diagram.*

d. Application of input voltage also activates the blower which provides cooling air for the converter and, to some extent, for the host system. Input power is controlled by a front panel ON-OFF switch which activates the control circuits (when closed) to initiate operation. If the ON-OFF switch is in the OFF position, a front panel FAULT light is automatically activated.

e. The 20 kHz switching converter utilizes two "half-wave forward" converters, each operating at 20 kHz but 180° out of phase. The pulse width drive to the individual converters is automatically changed to control the duty cycle and hence, the average power delivered through the isolation transformer to the output rectifier filter. Since the switching converter is, in effect, on and off, the converter and regulator mechanism is highly efficient, with losses primarily assigned to the switching transistors in the primary, and the rectifiers in the secondary.

f. The output of the rectifiers is a 40 kHz rectangular waveform (in effect, full wave rectification of the 20 kHz square wave). The rectangular (pulsed) waveform from the rectifiers is averaged by an output filter to obtain smoothed DC which, in turn, is delivered through the isolation diodes to the specified loads. As the output load increases, the pulse width and hence, the average power is increased automatically by the regulator loop to maintain the output voltage constant. The output pulse width is also automatically increased as the output voltage is reduced in such a manner as to maintain the output voltage constant.

g. The output is monitored both before and after the isolation diodes. The monitor circuit after the regulation diodes regulates the load voltage as previously described. When the converters operate in redundancy, the converter set to the higher output voltage (as little as a few MV differential) will, in effect, be on line, and the converter set at a slightly lower voltage will be "on standby".

h. The sense lines which regulate the voltage after the diodes will accordingly sense that the output voltage is "too high" and attempt to shut down the converter to achieve the set voltage. The sense line before the diodes, however, insists that the output voltage prior to the diodes is maintained approximately 0.5V higher than the set voltage. This ensures that the standby converter will be instantly ready to take over if the on line converter fails. Accordingly, the sense line before the isolation diodes regulates in the standby mode and the sense lines after the diodes regulate in the operate mode. The output circuits are isolated from the input circuits both by the isolation transformer and by light-coupled transistors in the

feedback and control loops.

i. The converter incorporates electronic current limiting and short circuit protection which limits the maximum current that the converter provides to approximately 85A so that overload will not cause any damage. If the converter is short circuited, the current limit circuit "folds back" and limits the short circuit current to approximately 35A until the short is removed, at which time the converter automatically recovers.

j. Other fault circuits include undervoltage detection which activates the front panel FAULT light if output voltage is below 4.5V, and overvoltage protection which turns off the power supply automatically if the output voltage exceeds 6.25V. Overvoltage shutdown results in an undervoltage condition which automatically activates the front panel FAULT light.

k. Front panel controls and indicators include the ON-OFF switch, FAULT lamp, voltage adjust, test points, output voltage (P1 and P2 connectors) after the isolation diodes, and output voltage before the isolation diodes. All test points are isolated with a 470 ohm resistor which prevents damage in the event the test point is shorted.

## 1-14. Circuit Description

(fig. FO-2)

### a. EMI Filter and Related Components (fig. 1-3)

(1) Input power is applied to P1A1 with the return on P1A2 and/or P2A1 and P2A2. Filter choke L1, in conjunction with filter capacitors C4 and C5, prevent any differential EMI noise generated by the converter from reaching the input bus and similarly, prevent any noise on the input bus from reaching the converter and/or the output.

(2) L2 is a common mode choke which, in conjunction with the capacitors C1 and C2, filter any common mode noise generated by the converter from reaching the input line and similarly, prevent common mode noise on the AC line from reaching the converter and/or the output.

### NOTE

Common mode noise is defined as noise voltage variations between the two lines and ground. Differential noise is defined as noise between the input lines. Differential noise is typically generated by load variations or switching on the power line whereas common mode noise is generated by noise on the line and stray capacitance to case ground which, in effect, sets up potential ground circuits.

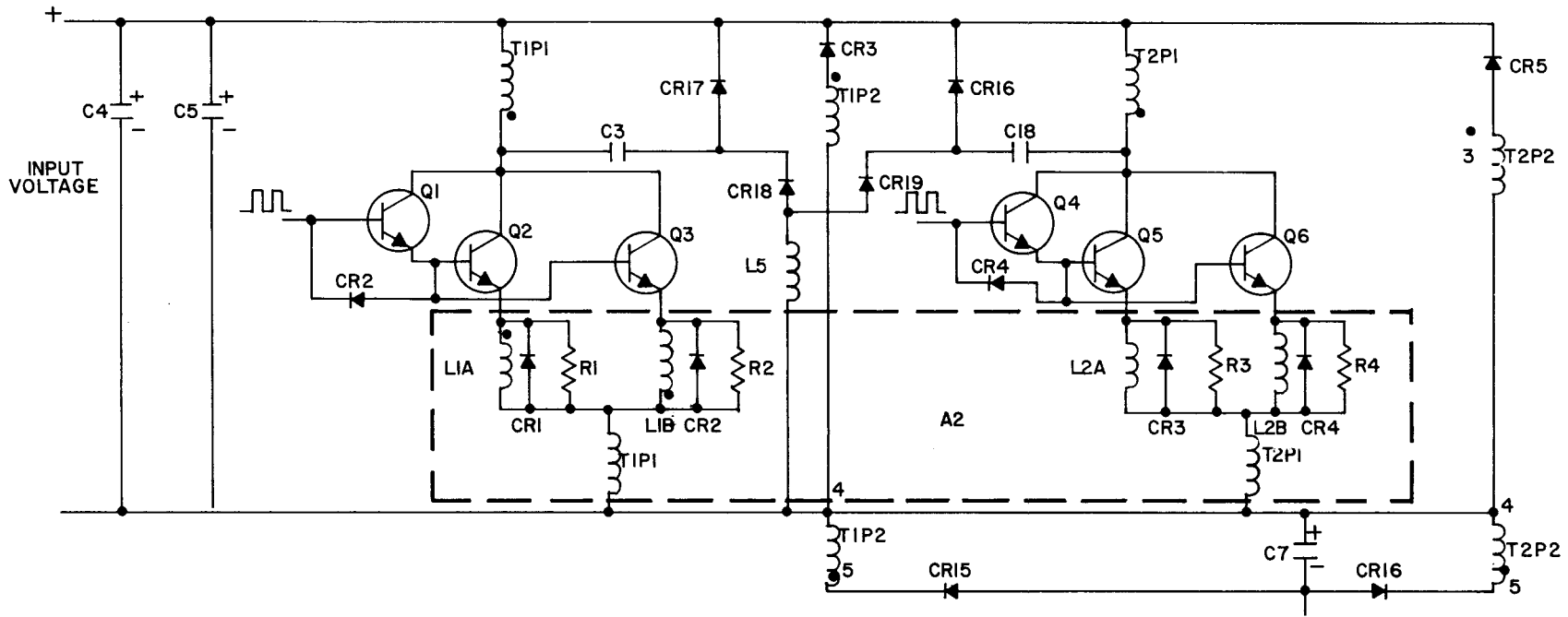

## EL9AW003

Figure 1-3. EMI Filter and Related Components and 20 KHz Switching Converter.

(3) Rectifier CR1, in effect, shorts the input bus if reverse voltage is applied and accordingly trips the system circuit breaker and prevents damage to the power supply. Blower B1 provides cooling air for the power supply and the system.

(4) The front panel ON-OFF switch applies power to the control circuits which in turn activate the 20 kHz switching converter. When switch S1 is in the off position or if the power supply is not operating properly, the front panel fault light DS1 is activated.

*b. 20 kHz Switching Converter (fig. 1-3).*

(1) Power transistor Q2 is turned on and off by external drive circuits with the waveform as shown in figure 1-3. When the input voltage to the base of Q2 is positive, the transistor conducts and current flows through the primary of T1P1. The voltage on the collector of Q2 decreases to the saturation voltage of the transistor (on the order of 1V).

(2) By transformer action, as current flows in the primary, it also flows in the secondary of T1 through filter capacitor C15 and filter choke L3. When the pulse on the base of Q2 ends, the voltage on T1P1 goes up to approximately twice the input line voltage. When this occurs, transformer primary T1P1 conducts through CR5, which delivers the magnetizing current in the primary of T1 back to the line in a dissipationless fashion. This limits the voltage on Q2 to approximately twice the input line voltage. The voltage on the collector of Q2 remains in this condition until the magnetizing current is reduced to approximately zero, at which time the voltage on the collector of Q2 returns the line voltage as indicated. The transformer has now been "reset" and awaits the next pulse.

(3) The waveform on the secondary of T1S1 is identical in shape to the voltage on the primary, but reversed in polarity and adjusted in magnitude by the turns ratio. Rectifier CR6 permits current to flow to the load when Q2 is conducting, which in turn causes current to build up in filter choke L3. When Q2 stops conducting, CR6 blocks the negative pulse and the current flowing in L3 conducts through CR10 until the next pulse occurs. Accordingly, the action of the choke is to convert the pulsating output voltage into a continuous DC current. Output filter capacitor C15 smooths the output voltage and eliminates ripple and noise from the output. If the pulse width is increased, the average voltage at the output will increase, and accordingly, by controlling the pulse width, the output voltage may be regulated independent of line and load conditions.

(4) The voltage on EMI filter capacitors C4 and C5 supplies power to two half-wave forward converters which, in turn, activate the primaries of T1P1 and T2P2, respectively. It will be noted by review of

the drive waveforms that the two converters are operating 180° out of phase.

(5) The components shown on figure 1-3 are mounted on the main frame assembly with the exception that the components shown within the dashed lines are located on printed circuit board (PCB) A2. The power transistors which activate transformer T1 are Q2 and Q3 operating in parallel. The network L1A-CR1-R1-L1B-CR2-R2 on PCB A2 assures current-sharing between Q2 and Q3 during the on pulse. In effect, L1A and L1B operate as an inter-phase transformer so that if Q2 is conducting more heavily than Q3, the emitter of Q3 will be pulled negative by transformer action to assure that the currents are equalized. CR1-R1-CR2-R2 assures reset during the off time. Transformer T1 on PCB A2 is a current transformer which detects the instantaneous current flowing within either set of switching transistors. The secondary of this current transformer is monitored, and if for any reason the current in the switching transistors exceeds the predetermined safe value, the pulse is narrowed to limit the current at all times independent of line, load, or fault conditions to a safe value.

(6) The two power switching transistors are driven by a Darlington transistor with a fast turnoff diode (Q1-CR2, Q4-CR4). The Darlington transistor reduces the amount of drive current required by the switching transistors, and the fast turnoff diode permits back bias of the switching transistors during the turnoff mode to reduce the storage time.

(7) The reset winding of power transformer T1 is tapped at terminal 4, and the winding between terminals 4 and 5 is rectified and filtered by CR15, CR16, and C7 to generate approximately 6V. This voltage is subsequently used in the control circuits for reverse biasing the switching transistors during the turnoff period.

(8) During the interval when the switching transistors are either turning on or off, there will be commutation losses since the voltage across the transistor may be high while currents are simultaneously flowing in the transistor. These losses are minimized by the commutation network consisting of C3, CR18, CR19, CR17, and CR16. Operation of the commutation network for transformer T1 is as follows. When Q2 and Q3 are turned off at the end of the pulse, the magnetizing and residual currents flowing in the primary of T1 flow into capacitor C3 and then returned to the positive bus. During this phase, C3 is charged to approximately the input line voltage. When Q2 and Q3 are turned on at the beginning of the next pulse, the cathode of CR18 is driven negative by an amount approximately equal to the line voltage. This action causes current to flow through CR18 and inductor L5 in a "resonant" charging action, which,

in effect, reverses the charge on capacitor C3. The result is that the switching losses previously dissipated in the switching transistors are harmlessly recycled in the commutation network with a corresponding improvement in efficiency and reduction in transistor heating. The same process is repeated during the alternate half cycle by the equivalent components associated with transformer T2.

*c. Output Power Section (fig. 1-4).*

(1) Power transformers T1 and T2 each have two secondaries and each secondary incorporates its own rectifier (CR6 through CR9). Since the transformers are 180° out of phase, the output from the rectified transformer output is a 40 kHz rectangular waveform approximately 7V in magnitude. Current sharing through the rectifier is provided by the separate secondaries and by the natural drop in power wiring.

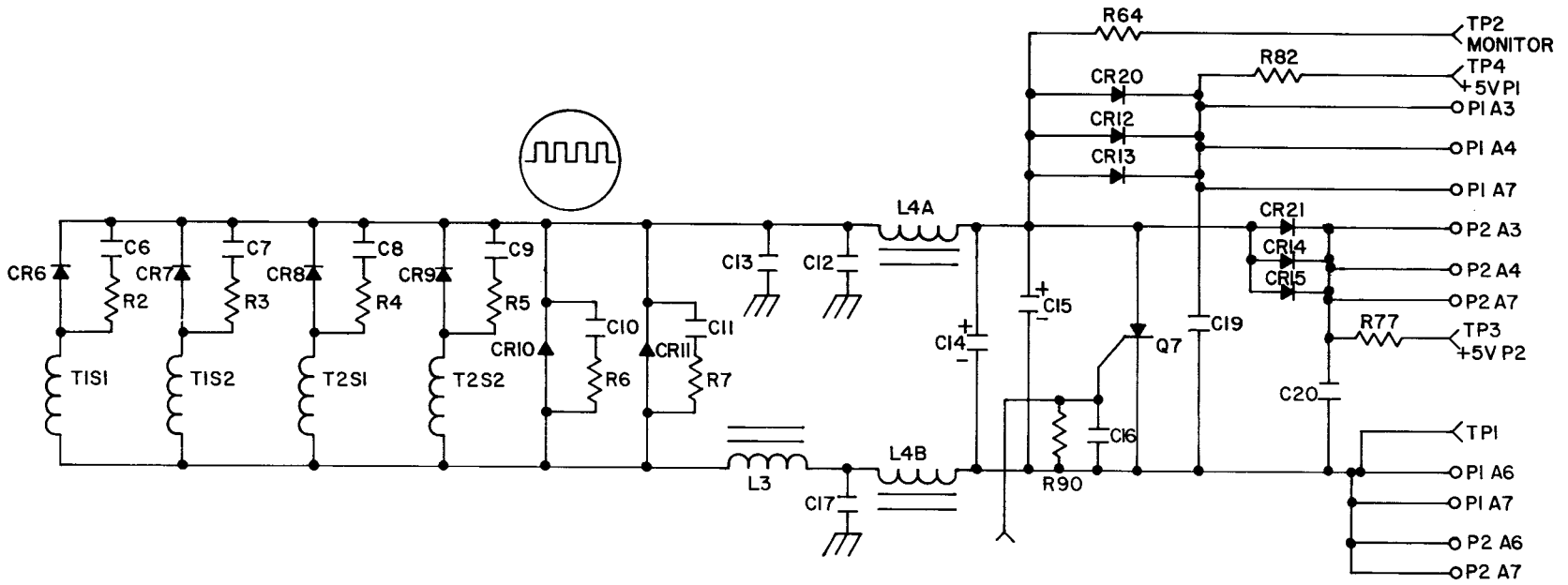

**EL9AW004**

Figure 1-4. Output Power Section.



(2) CR10 and CR11 are the coasting diodes through which the current from choke L3 passes during the off position of the cycle. The RC networks across each rectifier are commutation networks to minimize noise and to protect the Schottky rectifiers from transient spikes. Choke L3, in conjunction with output capacitors C14 and C15, acts as a low pass filter to eliminate the AC components and only pass the DC to the output; i.e., the DC is smoothed by the filtering process. Capacitors C12, C13, and C17 and common mode choke L4 act as a common mode filter.

(3) Diode steering to P1 is provided by CR20, CR12, and CR13 operating in parallel. The output voltage prior to the diodes is monitored by resistor-protected test point TP2 and the output voltage after the diodes is monitored by resistor-protected test point TP4. The output voltage is steered to P2 through CR21, CR14, and CR15, and the output voltage at the connector is monitored by resistor-protected test point TP3.

(4) The return is connected to P1 and P2 and is monitored by test point TP1. Capacitors C19 and C20 are utilized for “despiking” the output after the redundant rectifiers.

*d. Secondary Regulator and Control Circuits.*

(1) The secondary regulator circuit monitors the voltage before the redundant diodes and on the output terminals of P1 and P2. An internal voltage reference is generated. This is compared with the above voltages by three separate comparators whose outputs are collated and, in turn, activate a light-coupled transistor which controls the pulse width generator in the DC-DC converter. When the light-coupled transistor is in the off condition, the pulser is turned “full on”, thereby generating maximum output volt-

age. When the output voltage before the diodes reaches the predetermined maximum, the light-coupled transistor is turned on, which in turn narrows the pulse width and limits the maximum voltage. This assures a minimum standby voltage when the power supply is operating in the standby “redundant” mode.

(2) The output voltage at P1 and P2 is monitored by separate error amplifiers which compare these output voltages with the same reference. In the event that the output voltage at one of the connectors is below preset minimum, the error amplifier will override the monitor amplifier and turn off the light-coupled transistor, thereby widening the pulse width until the desired output voltage at the connector is achieved.

(3) The desired output and monitor voltages are set by changing the common voltage reference, and accordingly, the monitor on the two connectors outputs will be set to the same voltage by the single adjustment. The monitor voltage comparator (before the diodes) is set at approximately 0.3V higher than the desired output voltage at the connector which compensates for the redundant diode drop in the near no load condition.

*e. Regulator Loop (fig. 1-5).*

**NOTE**

Redundant diodes and output connectors are shown in simplified form. The regulator components shown within the dashed lines are part of PCB A1, with the exception of the +5V monitor voltage adjust which is on the front panel.

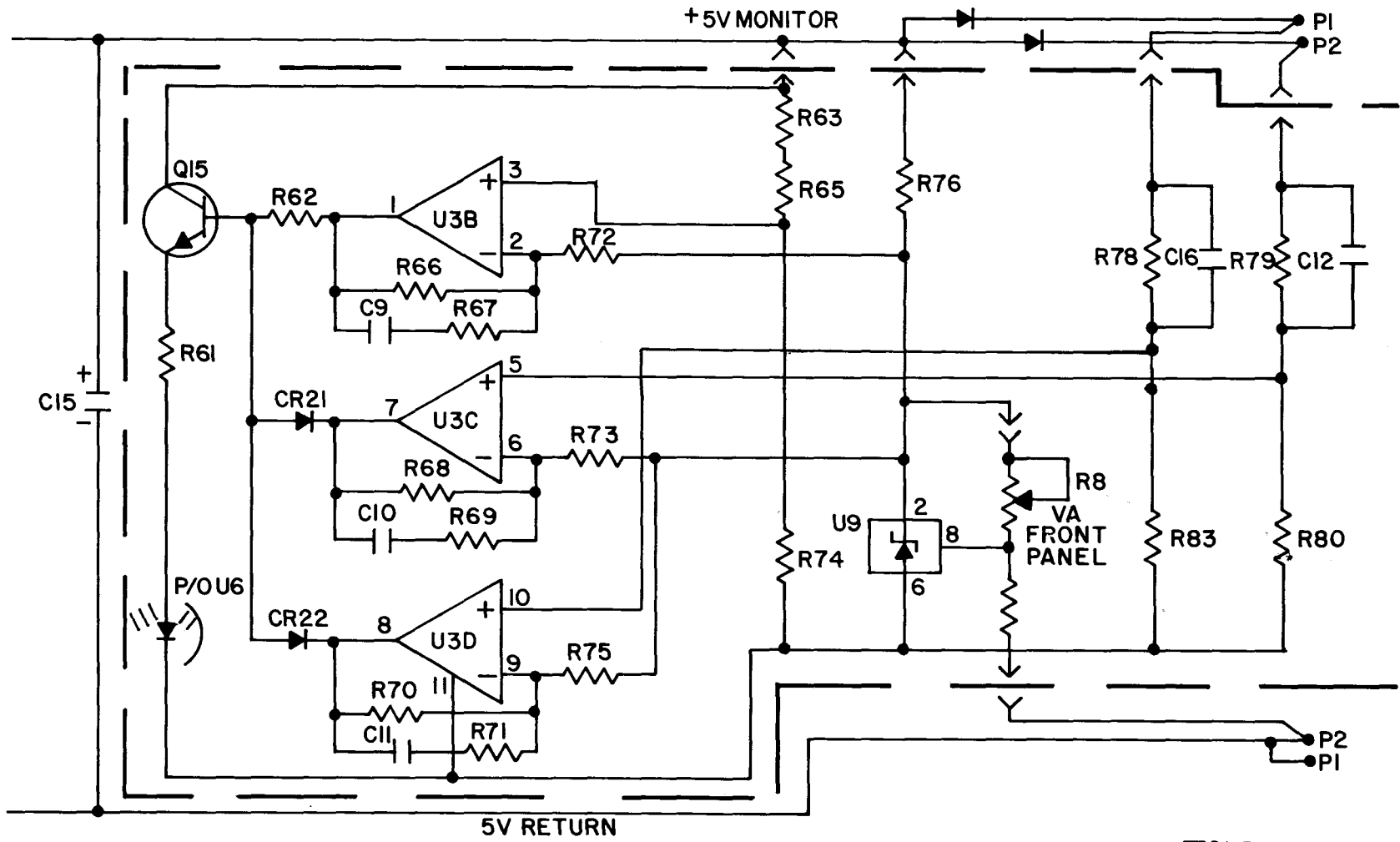

# EL9AW005

Figure 1-5. Regulator Loop.

(1) U9 is an adjustable voltage reference which is activated from the +5V monitor by resistor R76. U9 is normally set at approximately 3V by front panel voltage adjust potentiometer R8. U3 contains four operational amplifiers designated A, B, C, and D respectively, and the voltage reference generated by U9 is applied to the negative differential terminal of U3B, U3C, and U3D. For example, if the reference is larger than the voltage to which it is compared, the output of the above operational amplifiers is reduced to near zero.

(2) The voltage before the redundant diodes is sensed by resistive divider network R63-R65-R74. If the monitor voltage is too low, the output of U3B will be low, thereby removing drive from the base of transistor Q15 and turning off light-coupled transistor U6. This in turn increases the pulse width until the desired keep-alive voltage is achieved.

(3) The voltage on P2 is monitored by resistive divider R79-R80 and applied to the positive differential terminal of U3C. If the output voltage is too low, the output of U3C will be reduced to near zero, hence removing the drive of Q15 through CR21 to widen the pulse width in a regulatory fashion. In a similar manner, the voltage on P1 is monitored by resistive divider R78-R83 and applied to the positive terminal of U3D. Again, if the voltage on P1 is low, U3D will turn off Q15 through CR22, thereby broadening the pulse width in a regulatory fashion.

(4) It should be noted that the output regulators can only turn off the light-coupled transistor, whereas the monitor regulator turns it on to limit the voltage. When the power supply is on standby in a redundant mode, the output from the operating power supply keeps the voltage at P1 and P2 higher than the set voltage on the standby supply, and accordingly, U3C and U3D are inactive. During switch-over to operate, the appropriate regulator loop turns off the light-coupled transistor to assure the desired output voltage without a "glitch" in the output.

(5) Capacitors C12 and C16 provide speed-up in the detection network for fast and stable transient response. The feedback resistors across U3B, U3C, and U3D set the gain of the amplifier loop, and the RC networks in the feedback loop determine the transient (high frequency) response of the regulator.

*f. Undervoltage and Overvoltage Detection Circuits (fig. 1-6).*

(1) The undervoltage and overvoltage detection circuits monitor the voltage before the redundant diode. In the event of an undervoltage condition, the fault lamp and a fault indicating relay are activated. In the event of an overvoltage condition, a light-coupled transistor is activated which permanently turns off the pulse width modulator. The circuit may be restored after being tripped off by momentarily setting the ON-OFF switch on the front panel to the OFF position.

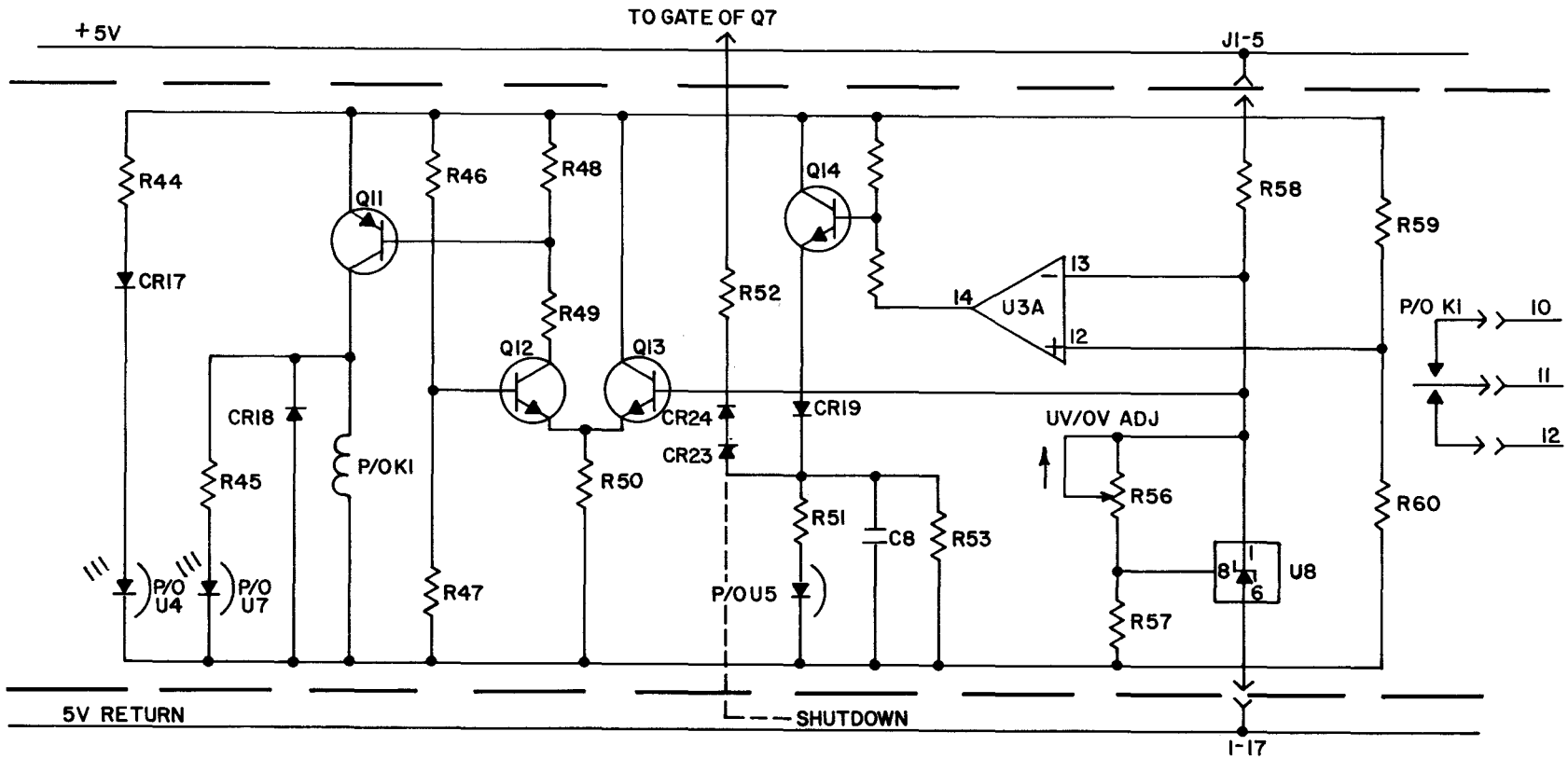

**EL9AW006**

Figure 1-6. Undervoltage and Overvoltage Detection Circuits

(2) The components inside the dashed lines are mounted on PCB A1. Operation is as follows: An independent voltage reference for the undervoltage and overvoltage circuits is generated by series dropping resistor R58, variable zener reference U8, and resistive divider R56 (undervoltage/overvoltage adjust R57). It is normally set to approximately 2.8V. The overvoltage comparison is performed by U3A which compares the output voltage as monitored on resistive divider R59-R60 with the reference. In the event of an overvoltage condition, transistor Q14 is turned on, which in turn activates light-coupled transistor U5. CR19, in conjunction with C8 and R53, assures that overvoltage will not be erroneously actuated by spurious noise.

(3) Network CR23-CR24-R52 goes to the gate of the overvoltage SCR crowbar Q7, which simultaneously crowbars the output voltage downward. It should be noted that the contacts of fault indicating relay K1 are brought to the output through a toggle switch (not shown on fig. 1-6), which connects the

relay contacts in the proper configuration to indicate faults in the AN/TCC-38 and AN/TYC-39 systems. The switch must be positioned in accordance with the system in which the converter is used.

(4) Light-coupled transistor U4 is normally activated through R4 and CR 17 when the converter is on. Under short circuit conditions U4 turns off. This tells the current limit circuits in the primary regulator that the power supply is shorted, which in turn generates the foldback current-limiting short circuit protection.

*g. Primary Control Circuits (fig. 1-7).*

(1) The primary control circuits include a voltage regulated power supply to assure proper operation; an integrated circuit which is a combined clock, pulse width generator, voltage reference and appropriate operational amplifiers to generate the drives to the half wave forward converter; and appropriate start-up (soft start), overvoltage, current limiting, and fault circuits. All of these components are located on PCB A1.

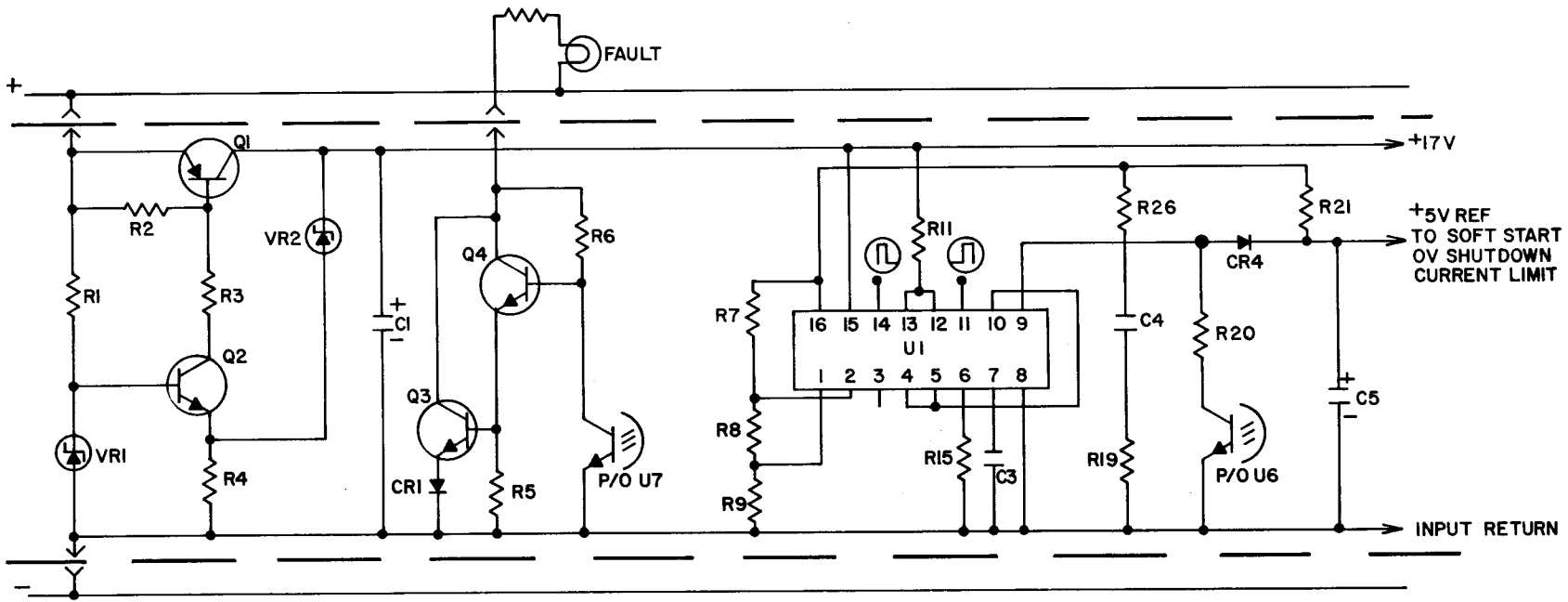

**EL9AW007**

Figure 1-7. Primary Control Circuits.

(2) The voltage regulator operates from the filtered Dc input and delivers regulated 17 VDC to the primary control circuits. The filtered input voltage is applied through resistor R1 to generate an 8V reference across zener diode VR1. Transistor Q2 turns on, thereby turning on transistor Q1, and the output voltage of the regulator rises towards a nominal 17V as measured across C1. When the output voltage reaches approximately 17V, zener diode VR2 conducts, thereby raising the voltage on the emitter of Q2, which limits the drive to the regulator loop to maintain the output voltage constant, independent of line and load condition.

(3) U7 is part of the undervoltage light-coupled transistor described previously. In the event of an undervoltage condition, U7 turns off, thereby turning on Q4, which turns on Q3 and activates the front panel FAULT light.

(4) U1 contains all of the basic components necessary to drive a pulse width modulated DC-DC converter. The chip is activated by applying regulated 17V to pin 15. Pin 16 is an internal 5V reference, and terminals 1 and 2 are an input operational amplifier which can be used to control the output pulse width. It is not used in this case and resistive divider R7-R8-R9, in effect, makes it nonoperational. The chip generates pulse width modulated outputs as indicated on pins 14 and 15. The outputs are 180° out of phase and operate at 20 kHz. These outputs are used to drive the switching transistors in the DC-DC converter.

(5) The 20 kHz is generated inside the chip by dividing a 40 kHz clock by two. The frequency of the clock is determined by R15 and C3. Pin 9 is a comparator circuit which determines the duty cycle or pulse width delivered from pins 11 and 14. When the voltage on pin 9 is approximately at 4V, the pulses are at maximum width (approximately 50% duty cycle). As

the voltage on pin 9 is reduced, the pulse width narrows and reaches zero at approximately 2V on pin 9.

(6) Resistor R26 applies 5V to "pull up" pin 9, creating maximum pulse width and hence, maximum output voltage from the switching power supply. Pin 9 is pulled down through R20 by light-coupled transistor U6, which in turn is activated by the voltage regulating circuits described previously. Accordingly, when the output voltage reaches the desired level, U6 turns on, thereby reducing the voltage on pin 9 to achieve the desired regulated output.

(7) Capacitor C4 and resistor R19 limit the speed with which the voltage on pin 9 may be changed, and in effect, determine the transient response and the stability (no oscillations) of the power supply.

(8) When power is first applied to U1, a slow conversion from a very narrow pulse to the desired pulse width takes place so that the power supply builds up in a controlled manner and avoids unnecessary transients. Upon turn on, C5 is discharged and charges up through CR4, thereby controlling the pulse width during the turn on interval and generating the soft start desired.

#### *h. Drive Circuits (fig. 1-8).*

(1) Internal transistors from 10 to 11 and from 12 to 13 in U1 are turned on when the pulse is generated. The control voltage is applied through resistor R11 to pins 11 and 12, thereby activating these transistor circuits. When the transistor from pins 10 to 11 is turned on, a positive pulse is generated on the emitter of transistor Q5, driving it positive and causing it to conduct by the amount determined by R11. The collector of Q5 goes positive, thereby activating Q7 and driving the base of power inverter transistor Q1 to the on position. Resistor R12 limits the drive to the base of Q17 and R16 determines the current supplied to Q1.

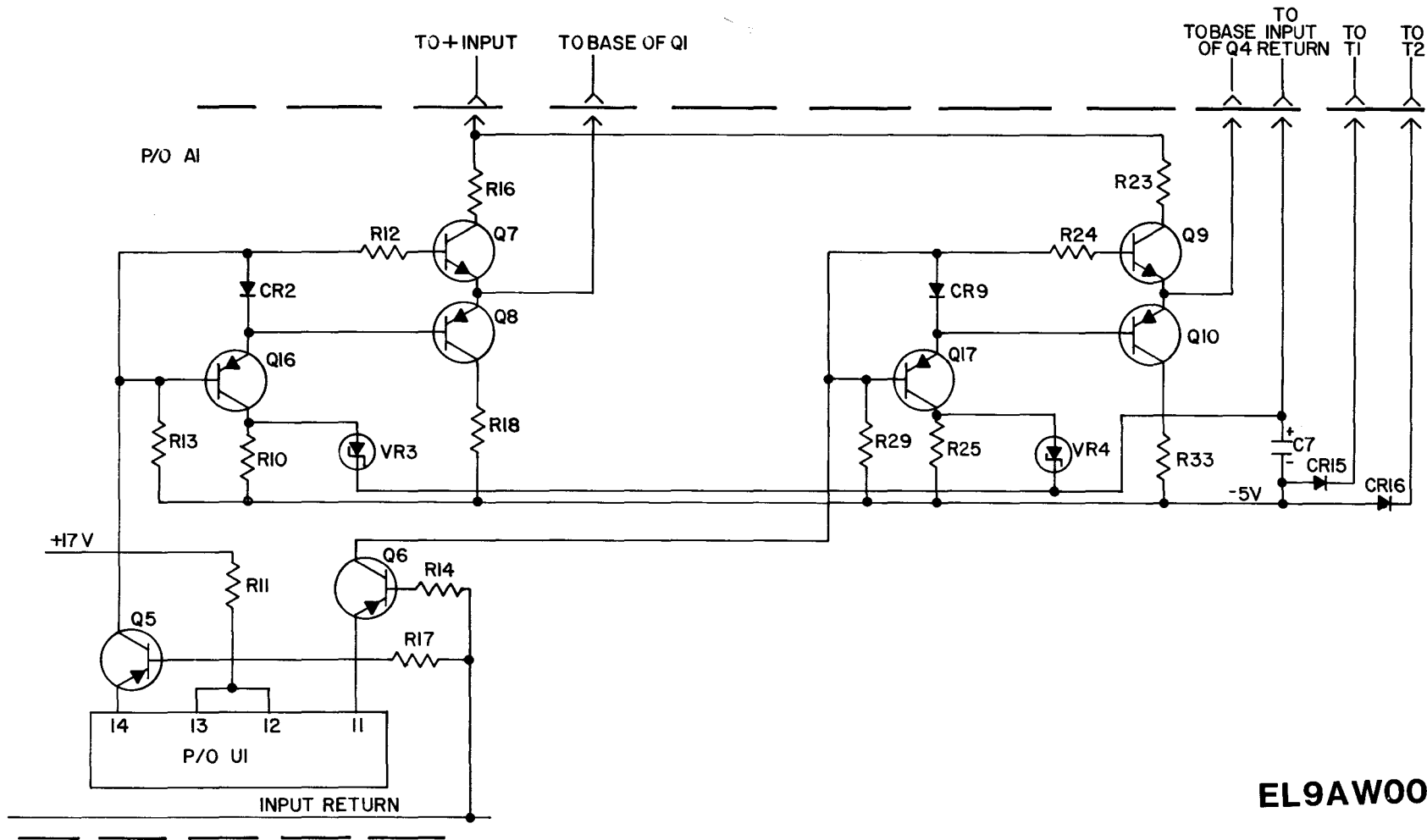

EL9AW008

Figure 1-8. Drive Circuits



(2) When the inverter is running, an auxiliary secondary on transformers T1 and T2 generates a -6V power source by the action of CR15, CR16, and C7 which is used for turning off the power transistors as follows: When the pulse from U1 is terminated, Q16 is turned on, thereby pulling the base of Q8 negative while simultaneously turning off Q7. This provides a reverse bias drive to the base of Q1, assuring fast turnoff. Zener diode VR3, in conjunction with R10, limits the negative voltage to which the base of Q1 can be driven, and resistor R18 determines the reverse current capability of the drive. On the alternate half cycle, Q6 activates Q9, Q10, and Q17 and drives Q4 on and off in the same manner.

*i. Soft Start Overvoltage and Current Limit Circuits (fig. 1-9).*

(1) Integrated circuit U2 contains four voltage comparators. The output of each comparator is a transistor which is turned on or off. U2C is the current limit detector which is activated by the secondary of current transformer T1. The output of the full wave bridge rectifier CR11 through CR14 is proportional to the current flowing in the two inverter transformers and appears across R38. This voltage is compared with a fixed current limit reference derived from the 5V reference by resistive divider R37-R35-R36. In the event that the instantaneous current in either half wave forward converter exceeds the prescribed amount, U2 turns on, thereby pulling down pin 9 of U1 through CR8, which narrows the pulse width in a current limiting fashion. C18 con-

trols the speed of response of the current limit circuit so that it is stable, and R22 discharges the soft start capacitor C5 so that if a power supply is short circuited, the soft start is utilized in the restart.

(2) When the output voltage is present, U4 is turned on, setting the current limit at the normal value. If the power supply is shorted, U4 is turned off, which reduces the current limit reference and causes foldback under short circuit conditions. Capacitors C6 and C13 prevent noise or spurious activation of the current limit circuit.

(3) U2B is the overvoltage detector chip which is normally biased in the off position by resistive dividers R31-R27 and R41-R42. In the event of any overvoltage condition in the output, light-coupled transistor U5 is activated, thereby turning on the overvoltage circuit, which simultaneously turns off pin 9 and discharges soft start capacitor C5. CR10 latches the overvoltage to the on position until the input voltage is temporarily interrupted, which generates a reset.

(4) U2A is the soft start circuit which monitors the 17V bus by way of resistive divider R39-R40 and compares it with the voltage reference R30-R28. When the bias reaches approximately 15V, U2 is turned off, thereby allowing the soft start to begin. If the bias drops for any reason, U2A turns on, stopping the pulser through CR5 and resetting the soft start through CR6 and R21. Resistor R26 creates a hysteresis in the bias detection level which eliminates chattering during turn on and turn off.

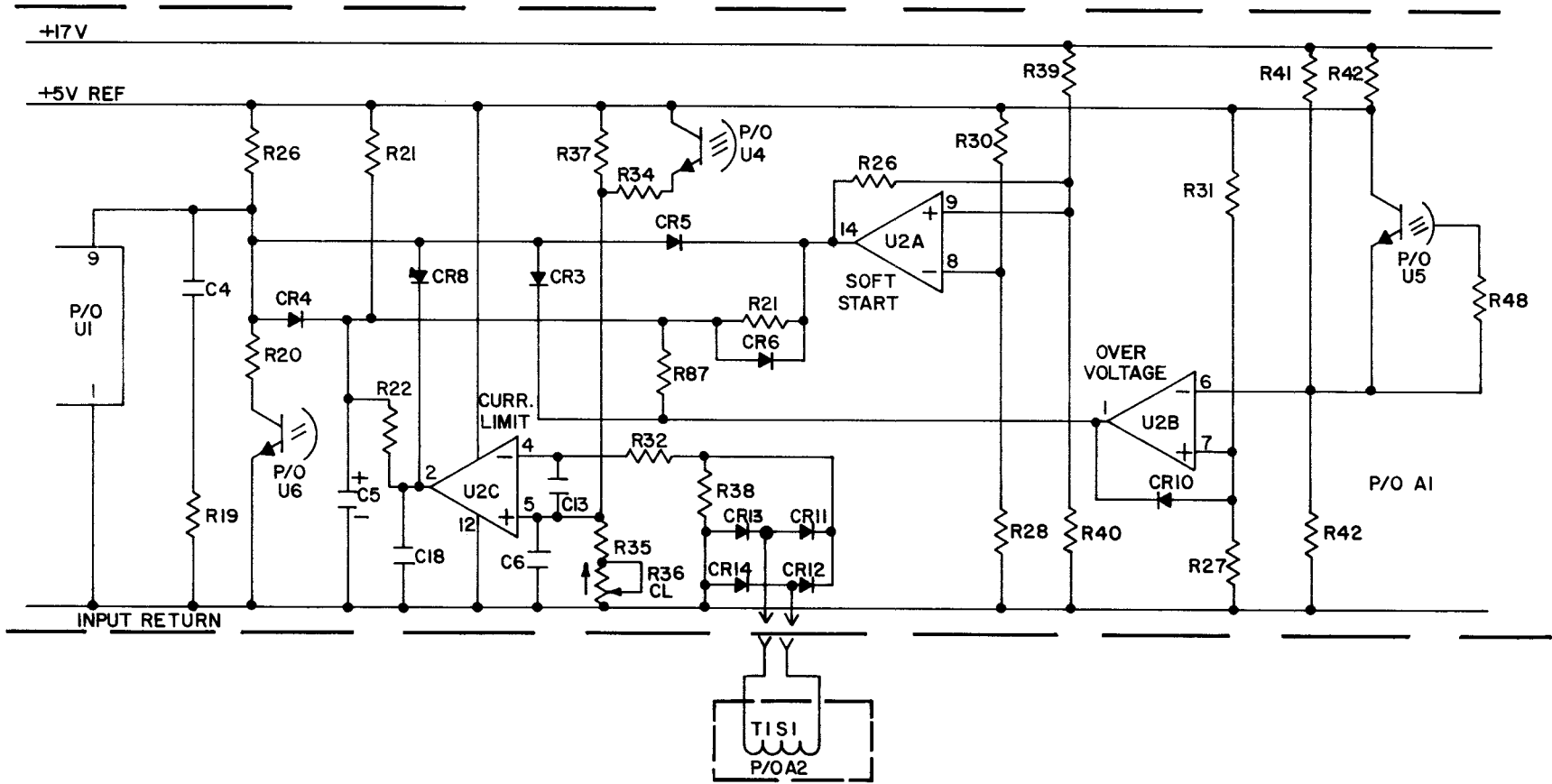

### EL9AW031

Figure 1-9. Soft Start, Overvoltage and Current Limit Circuits.

## CHAPTER 2

## GENERAL SUPPORT MAINTENANCE INSTRUCTIONS

## SECTION I. REPAIR PARTS, SPECIAL TOOLS, TMDE, AND

## SUPPORT EQUIPMENT

**2-1. Common Tools and Equipment**

For authorized common tools and equipment, refer to the Modified Table of Organization and Equipment (MTOE) applicable to your unit.

**2-2. Special Tools, TMDE, and Support Equipment**

Special tools, TMDE, and support equipment required by general support maintenance personnel are listed below:

- a. Tool Kit, Electronic Equipment TK-100/G.
- b. Repair Kit, Printed Wiring Board MK-772/U.
- c. Digital Voltmeter AN/GSM-64B.
- d. Multimeter ME-450/U.

- e. Oscilloscope AN/USM-281C.
- f. Power Supply PP-7545/U.
- g. Power Supply PP-7574/G.
- h. Variable Load DLP 50-150-3000.
- i. Megohmmeter ME-481/U.
- j. Fan, Tubeaxial MU3A1.
- k. Test Cable (see appx C).
- l. Jumper (see appx C).

**2-3. Repair Parts**

Repair parts are listed and illustrated in the repair parts and special tools list (RPSTL), TM 11-6130-429-40P, covering general support maintenance for this equipment.

## SECTION II. TROUBLESHOOTING

**2-4. General Troubleshooting Information**

Perform the bench tests in tables 2-1 and 2-2 to determine whether the converter is operational and to localize malfunctions. Improper readings obtained during bench testing indicate failed components and/or faulty wiring. Perform all tests and proceed to the detailed troubleshooting information to isolate the problem to a failed component.

**2-5. Troubleshooting Tables**

Table 2-3 contains detailed troubleshooting information to isolate malfunctions discovered during bench testing to specific circuits and/or components. Follow the procedures in proper sequence and perform the corrective actions to return the converter to serviceable condition.

**WARNING**

When troubleshooting or making repairs on this equipment be extremely careful. High current as high as 22 amperes is present in the output power section. Use insulated test probes when making the re-

quired voltage measurements. Always disconnect the test cable at rear panel plug P1, or otherwise interrupt the power supply to the equipment before touching any of the internal parts. Ground points of high potential to remove residual voltages.

**CAUTIONS**

Proper grounding is essential to satisfactory operation of the converter. Damage may result.

This equipment is transistorized; observe all cautions to prevent transistor damage. Do not make continuity or resistance checks other than those specified in the tests. Damage to the transistors and microelectronic devices, which can impair the performance of the equipment, may result if improper battery voltages and polarities are applied.

Table 2-1. Converter Operational Test

**NOTE**

Proceed to table 2-3 if the stated indication is not present.

Step	Procedure	Indication
1	a. Correct the equipment as shown in figure 2-1. b. Set converter ON/OFF switch to OFF and apply 26 Vdc to converter input.	FAULT lamp ON and fan runs.
2	Set converter ON/OFF switch to ON.	FAULT lamp OFF and converter delivers 75 ADC to electrical load.

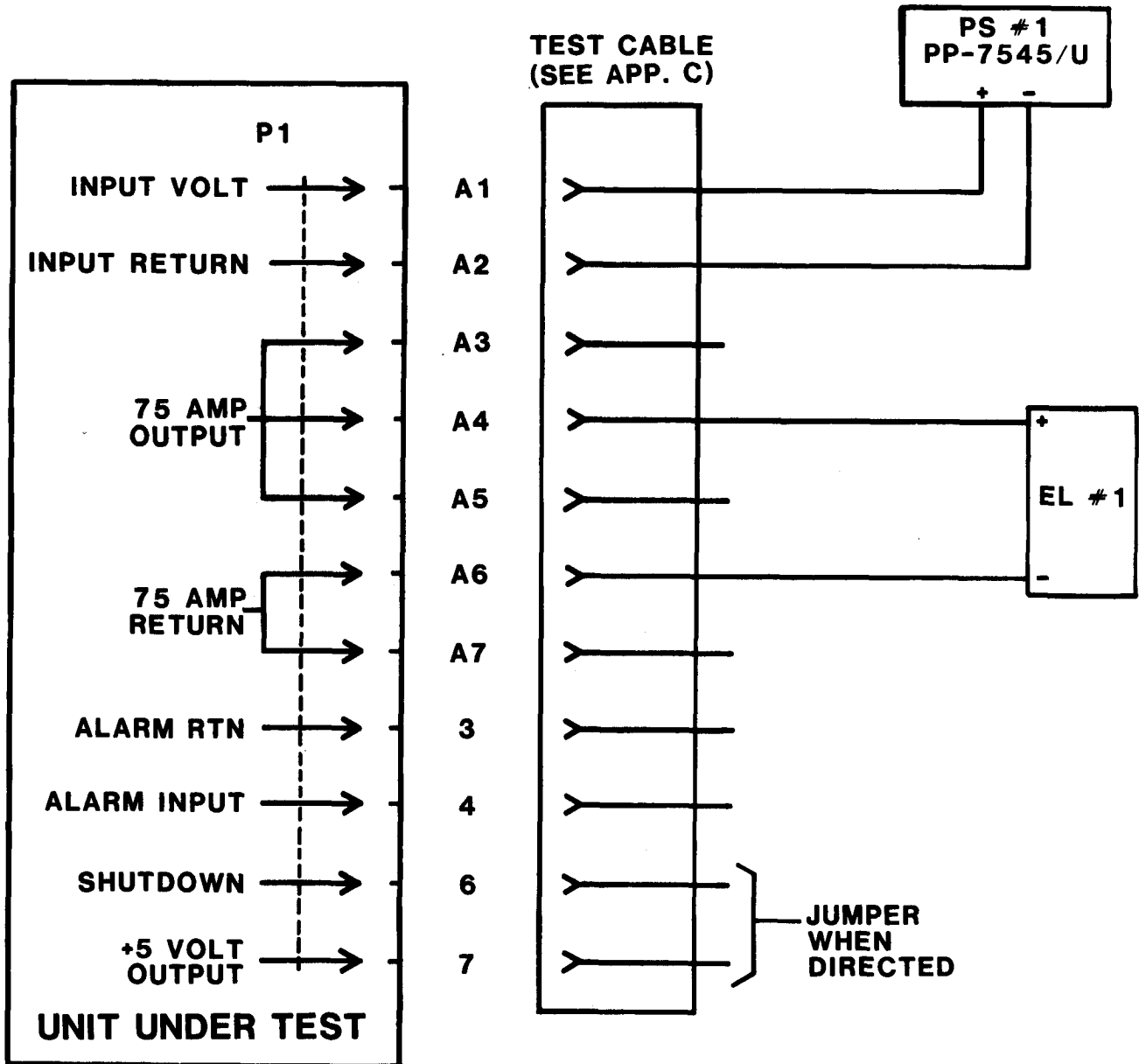

**EL9AW009**

Figure 2-1. Operational Test Setup.

Table 2-2. Converter Bench Test

NOTE

Proceed to table 2-3 if the stated indication is not present.

Step	Procedure	Indication
1	Set megohmmeter controls as follows: Test Voltage      200V Multiplier Dial    10M Measure resistance between the points listed below: <i>Negative Probe</i> <i>Positive Probe</i> Chassis                P1-A1 P1-A4                    P1-A1	Greater than 10 megohms.
2	Set megohmmeter controls as follows: Test Voltage      100V Multiplier Dial    10M Measure resistance between the points listed below: <i>Negative Probe</i> <i>Positive Probe</i> Chassis                P1-A4	Greater than 10 megohms.
3	Connect the equipment as shown in figure 2-2. Set digital voltmeter controls as follows: Range Selector    20 VDC Set oscilloscope controls as follows Channel 1 Deflection      500 MV/DIV,AC Display Mode                CH 1 Trigger Mode                Auto Trigger Slope                Positive sweep speed                20 $\mu$ sec/DIV	

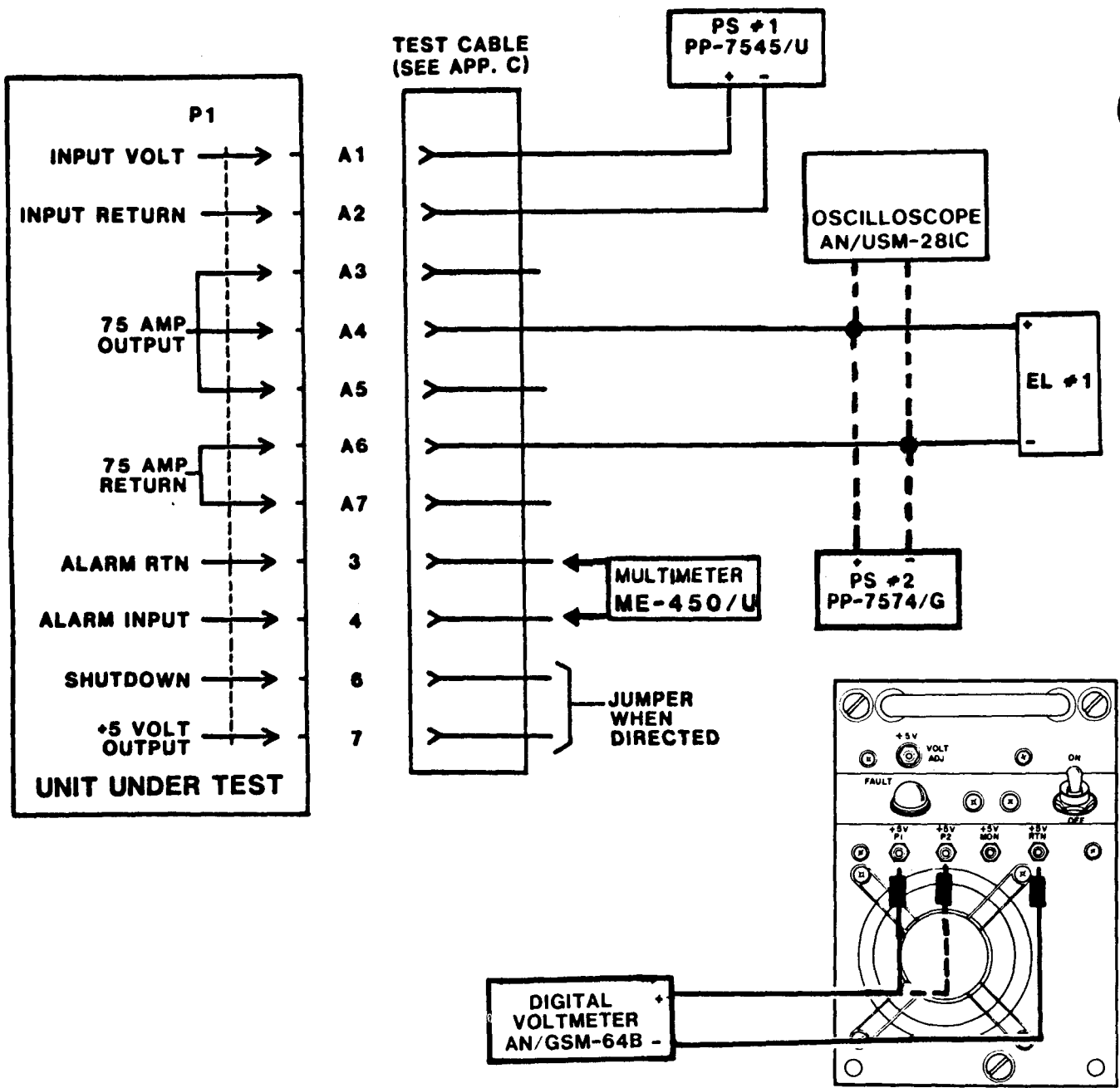

**EL9AW010**

Figure 2-2. Bench Test Setup.

Table 2-2. Converter Bench Test-Continued

Step	Procedure	Indication
	<p>d. Set electrical load controls as follows:</p> <p>Voltmeter Range           0-6V</p> <p>Ammeter Range            0-120A</p> <p>Resistor Range            0-30A/V</p> <p>e. Set converter ON/OFF switch to OFF and system selector switch to AN/TYC-39.</p> <p>f. Adjust variable input power supply to 25 VDC and observe converter.</p>	FAULT lamp ON and fan runs.
4	Set converter ON/OFF switch to ON.	FAULT lamp OFF and digital voltmeter reads +5 VDC $\pm$ 0.1.
5	Increase output loading on electrical load until current limit point is reached.	Current shall hold between 80 and 90A; output voltage decreases.
6	Readjust output load on electrical load to 75A; press short circuit button.	Current shall be between 10 and 45A.
7	Release short circuit button on electrical load.	Output voltage shall be +5VDC $\pm$ 0.1; output current shall be 75A.
8	<p>a. Loosen locking nut on converter front panel +5V adjustment potentiometer.</p> <p>b. Decrease output load to 2A.</p> <p>c. Adjust +5V potentiometer clockwise until overvoltage activates.</p>	Output voltage shall be less than 1V.
9	<p>a. Set converter ON/OFF switch to OFF and adjust +5V potentiometer fully counterclockwise.</p> <p>b. Set converter ON/OFF switch to ON. Decrease load to zero current and adjust input voltage to 30 VDC.</p> <p>c. Measure output voltage.</p>	Voltage reading shall be less than +4.75V.
10	<p>a. Increase load current to 75A.</p> <p>b. Lower input voltage to 21V.</p> <p>c. Adjust -5V potentiometer fully clockwise.</p> <p>d. Measure output voltage.</p>	Voltage reading shall be greater than +5.5V.
11	<p>a. Adjust +5V potentiometer so that output voltage is 4.75 VDC.</p> <p>b. Set converter system selector switch to AN/TYC-39.</p> <p>c. Adjust input voltage to 26 VDC.</p> <p>d. Observe front panel FAULT lamp.</p>	FAULT lamp OFF.
12	Using multimeter, check continuity between P1-3 and P1-4.	Continuity.
13	Using the electrical load, overload output until FAULT lamp is ON.	FAULT lamp ON; output voltage between +2.5 and 4.75 VDC.
14	Using the multimeter, check continuity between P1-3 and P1-4.	Open circuit.
15	<p>a. Adjust current to 75 VDC.</p> <p>b. Set converter system selector switch to AN/TTC-38.</p> <p>c. Using the electrical load, overload output until FAULT lamp is ON.</p> <p>d. Using the multimeter, measure voltage at P1-3 and P1-4 with P1-4 being positive.</p>	Voltage shall be between +2.5 and 4.75V.
16	<p>a. Adjust +5V front panel potentiometer until output reads +5.00 VDC.</p> <p>b. Connect a jumper between pins P1-6 and P1-7.</p>	FAULT lamp ON; output voltage shall be less than +2.0 VDC.
17	<p>a. Set converter ON/OFF switch to OFF.</p> <p>b. Remove jumper between pins P1-6 and P1-7.</p> <p>c. Connect a jumper between pins P1-A3 and P2-A3.</p> <p>d. Connect external power supply negative to P1-A6 and positive to P1-A3.</p> <p>e. Decrease loading on output to 0A.</p> <p>f. Set external Power Supply voltage to approximately 5.5 VDC.</p> <p>g. Set converter ON/OFF switch to ON.</p> <p>h. Measure voltage at +5V MON test point on converter front panel.</p>	Voltage shall be greater than +5.0 VDC.
18	<p>a. Set converter ON/OFF switch to OFF.</p> <p>b. Remove external power supply from P1-6 and P1-A3.</p> <p>c. Adjust input voltage to 30 VDC.</p> <p>d. Set converter ON/OFF switch to ON.</p> <p>e. Measure output voltage at front panel (+5V P1 and +5V RTN).</p>	Voltage shall be +5V and $\pm$ 0.1V.

Table 2-2. Converter Bench Test-Continued

Step	Procedure	Indication
19	a. Increase output current to 75 ADC. b. Decrease input voltage to 21 VDC. c. Measure output voltage at front panel (+5V P1 and +5V RTN).	Voltage shall be +5V and ±0.1V. Ripple voltage shall be less than 150 MV.
20	Using the oscilloscope, measure the output ripple at P1 connector.	

Table 2-3. Troubleshooting

MALFUNCTION

TEST OR INSPECTION

CORRECTION ACTION

1. BLOWER NOT OPERATING, FAULT LAMP NOT LIT, ON/OFF SWITCH OFF.  
Using multimeter, check continuity of Input EMI Filter and related components.  
Repair wiring/replace defective components.
2. BLOWER NOT OPERATING, FAULT LAMP LIGHTED, ON/OFF SWITCH OFF.  
Using multimeter, check continuity from P1-A1/P2-A1 to + terminal of blower B1 and from P1-A2/P2-A2 to - terminal of B1.  
Repair wiring/replace defective blower B1.
3. BLOWER OPERATES, FAULT LAMP NOT LIGHTED, ON/OFF SWITCH OFF.  
Step 1. Using multimeter check continuity of bulb in FAULT lamp holder XDS1.  
Replace defective bulb.  
Step 2. Using multimeter, check continuity of wiring from L2B pin 4 to pin 1 of FAULT lamp DS1 and L2A pin 2 to pin 1 of DS1.  
Repair defective wiring/replace defective S1, R1 or lampholder XDS1.
4. BLOWER OPERATES, FAULT LAMP MAY OR MAY NOT BE LIGHTED, ON/OFF SWITCH ON, NO OUTPUT.  
Step 1. Input EMI Filter and Related Components (P/O Main Frame) Check. Using multimeter, check continuity from P1-A1 and P2-A1 to J2-2 and from P1-A2 and P2-A2 to J2-1, with ON/OFF switch (S1) ON.  
Repair wiring/replace S1. Replace defective component.

**NOTE**

The following tests require preliminary setup procedures.

*PRELIMINARY SETUP PROCEDURES*

1. Set converter ON/OFF switch to OFF.
2. Setup equipment as shown in figure 2-3.
3. Position cooling fan to circulate air around heatsink and rear panel.
4. Set test equipment controls as follows.



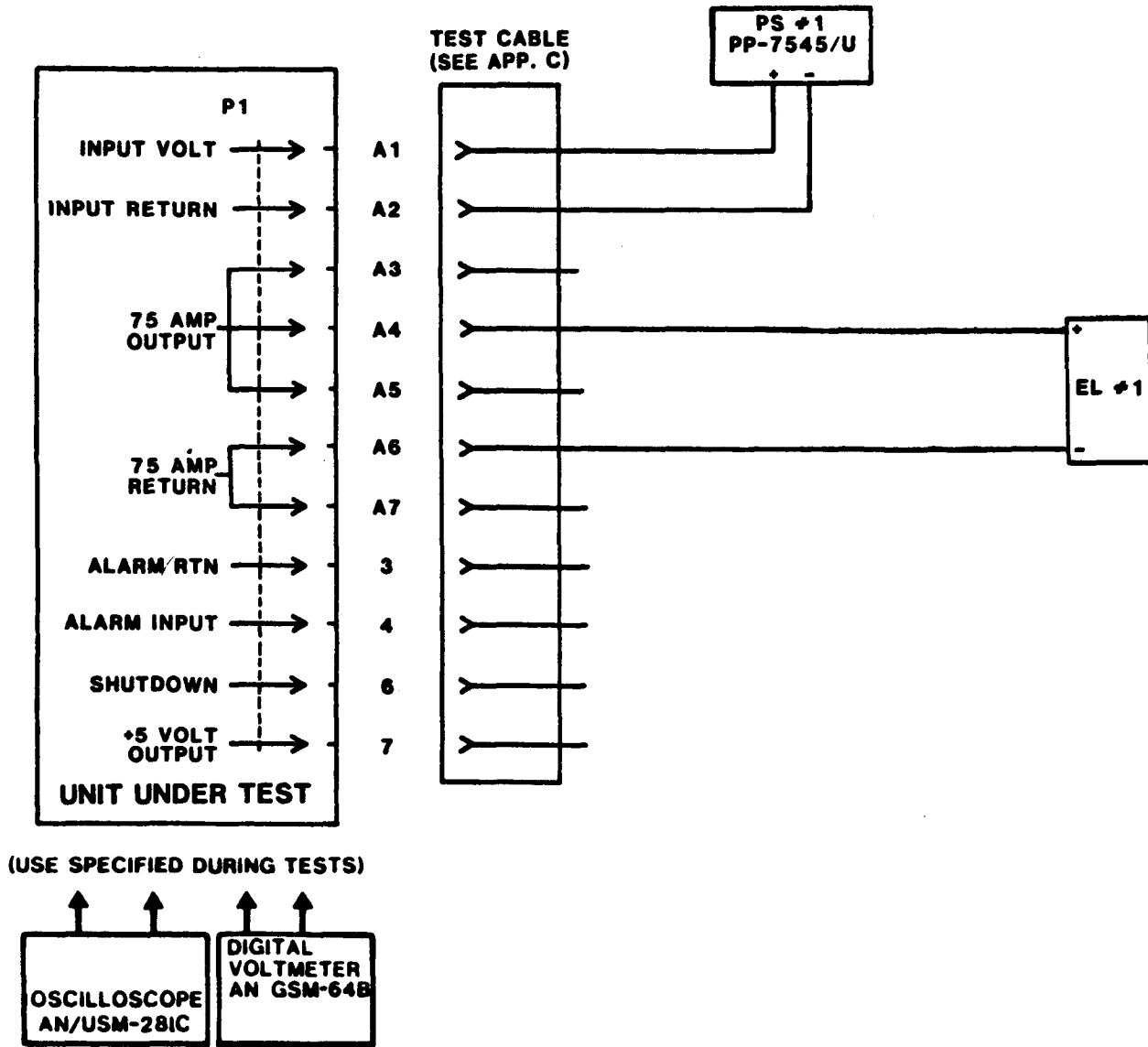

**EL9AW011**

Figure 2-3. Troubleshooting Test Setup #1.

Table 2-3. Troubleshooting-Continued

MALFUNCTION	TEST OR INSPECTION	CORRECTIVE ACTION
<i>Oscilloscope</i>		
	<i>Control</i>	<i>Setting</i>
	CH 1 Deflection	1V/DIV,DC
	Display Mode	Separate
	Trigger Source	CH1
	Trigger Mode	Auto
	Trigger Slope	Positive
	Sweep Speed	5 $\mu$ sec/DIV

Table 2-3. Troubleshooting-Continued

MALFUNCTION	
TEST OR INSPECTION	CORRECTION ACTION
<i>Power Supply</i>	Adjust to 26 VDC.
<i>Variable Load</i>	
<i>Control</i>	<i>Setting</i>
AC ON	ON
Voltage RANGE	6V
Current RANGE	180A
Mode	30A/V
DC CB	ON
<i>Converter</i>	
<i>Control</i>	<i>Setting</i>
System select	AN/TYC-39
ON/OFF	ON

**NOTE**

Voltages and waveforms given in the diagrams are not absolute and may vary slightly between units.

Step 2. 20 kHz Converter (P/O Main Frame) Check (fig. 2-4).

- a. Connect 10:1 scope probe ground to C4 + C5 (-) bus; connect probe to collector of Q2. Adjust horizontal and vertical positions, and trigger level of scope as required to observe display as shown in figure 2-5A.  
Check Q1, Q2, Q3 and associated components. Check A2 PCB components (fig. 2-6). Replace defective components.
- b. Leaving scope ground connected to - bus, connect scope probe to collector of Q5. Adjust scope as required to observe display as shown in figure 2-5A.  
Check Q4, Q5, Q6, and associated components. Check A2 PCB components (fig. 2-6). Replace defective components.

Step 3. Output Power Section (P/O Main Frame) Check.

- a. Connect 1:1 scope probe ground to L3-1; connect scope probe to cathode (+) bus bar of CR8, CR9, and CR11. Adjust scope as required to observe display as shown in figure 2-5B.  
Turn OFF and disconnect all equipment. Using multimeter, check CR6, CR7, CR8, CR9, CR10 and CR11 (2 to 3 ohms in forward direction) secondaries of T1 and T2, L3, C14, and C15.  
Replace defective component.
- b. Using voltmeter, check for  $+5 \pm 0.1$  VDC between P1-A3 (+) and P1-A6 (ground) of rear panel.  
Check CR12, CR13, CR14, CR15, CR20, CR21, and associated components. Replace defective component.

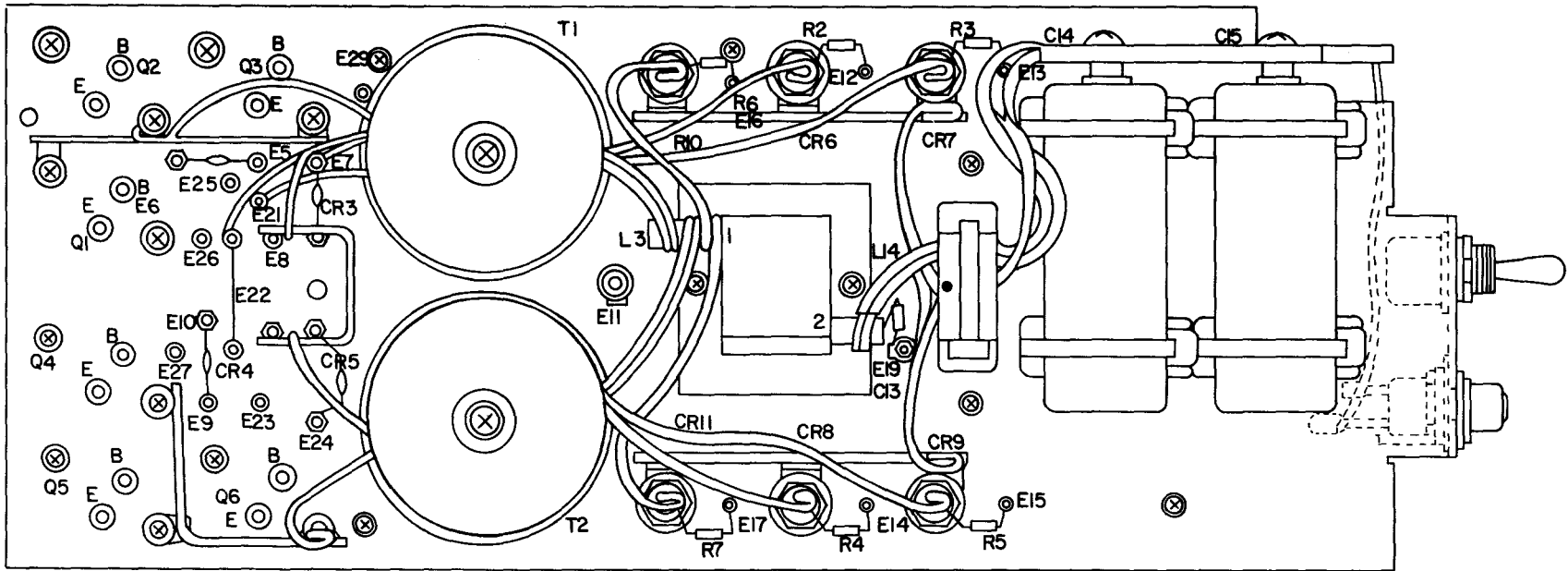

**EL9AW012**

Figure 2-4 ①. Heatsink Parts Location (Sheet 1 of 2).

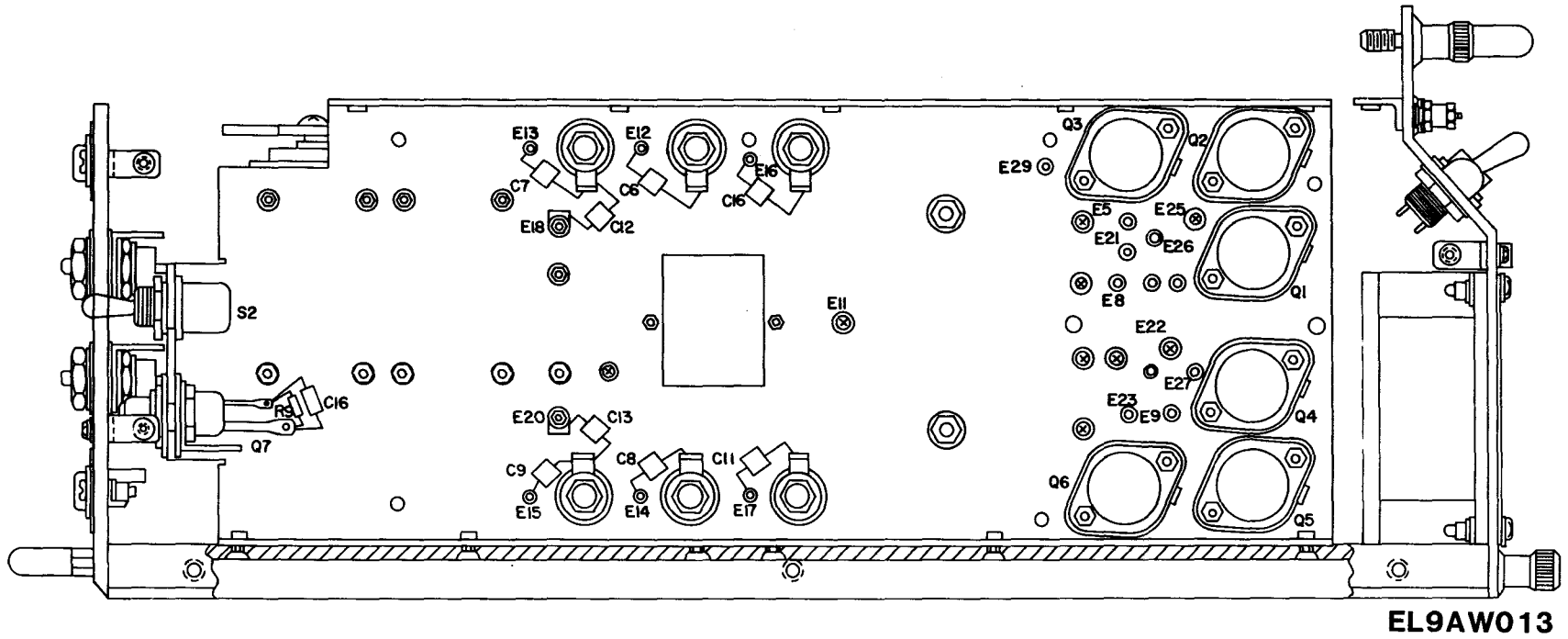
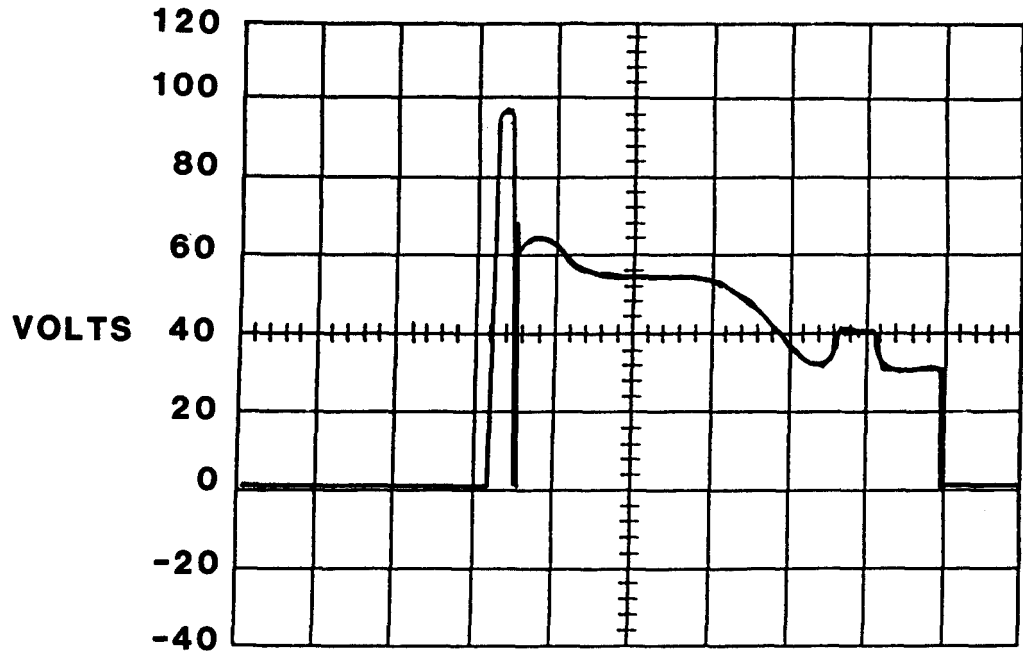

Figure 2-4 ②. Heatsink Parts Location (Sheet 2 of 2).

**EL9AW013**



TIME = 5 MICROSECONDS/DIVISION

2-5(A)

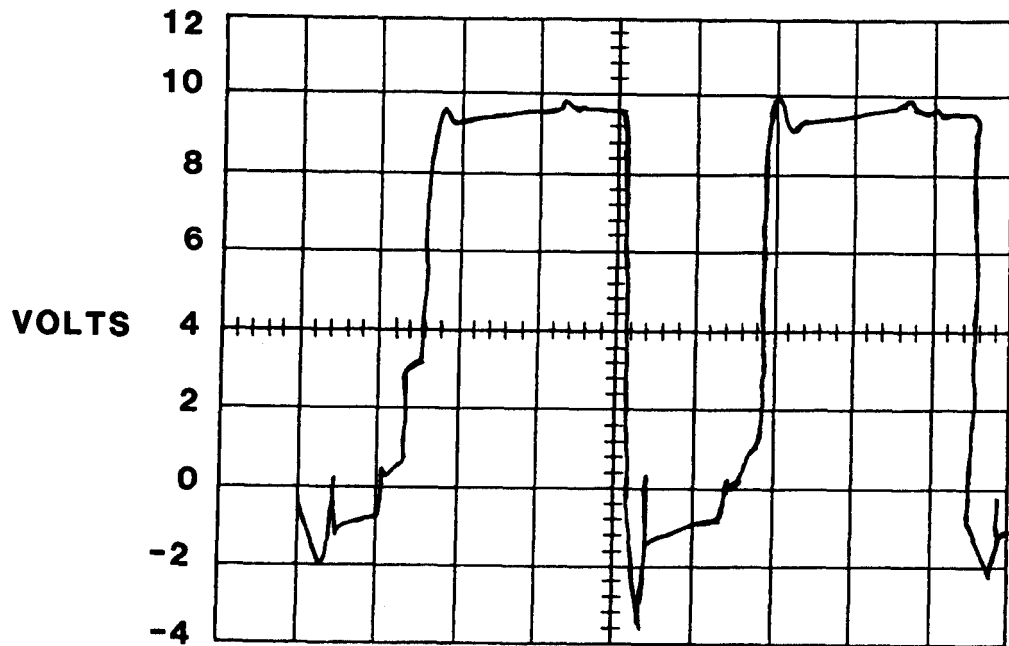

TIME = 5 MICROSECONDS/DIVISION

2-5(B)

EL9AW014

Figure 2-5. 20 kHz Converter and Output Power Waveforms.

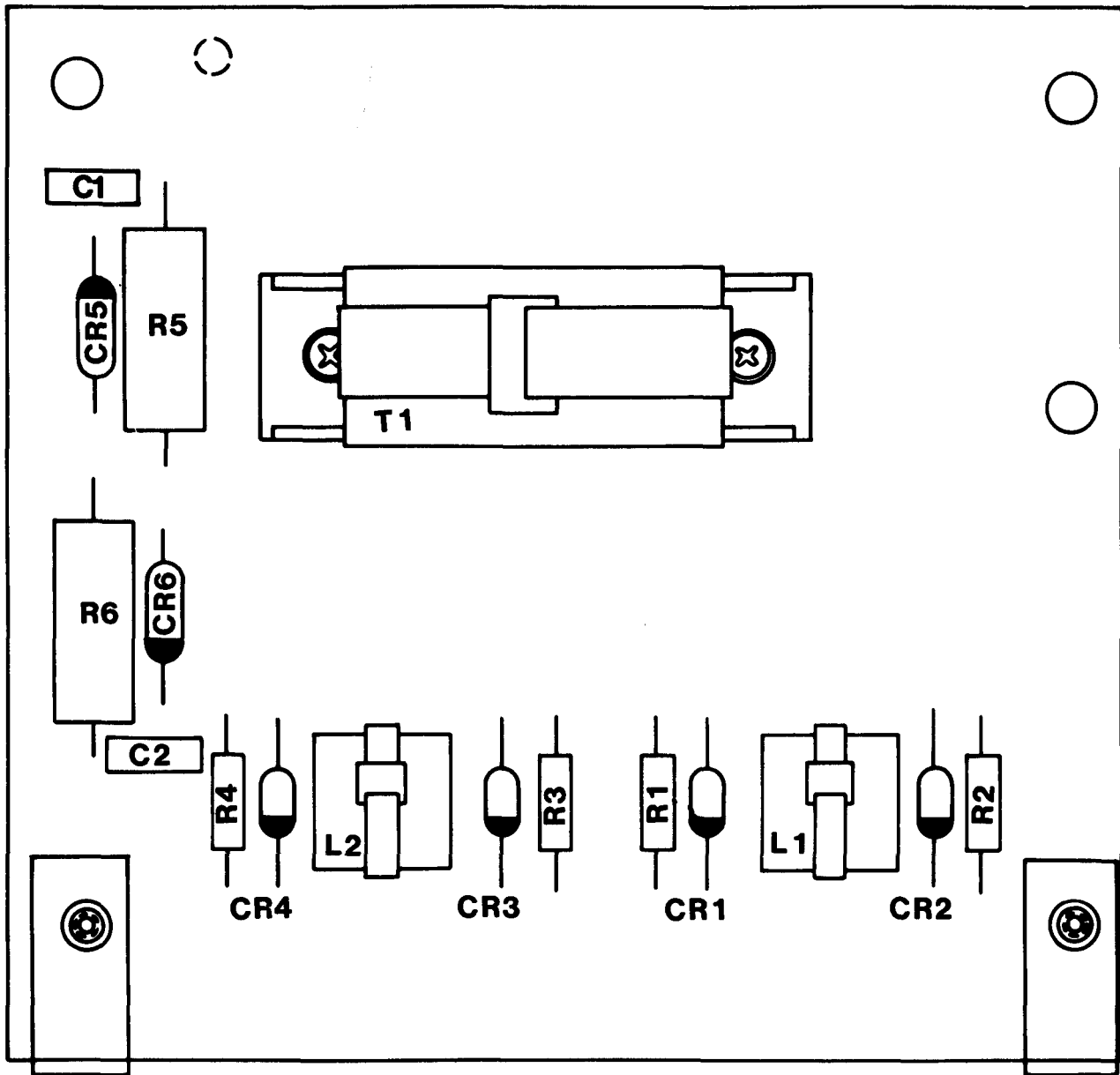

**EL9AW015**

*Figure 2-6. A2 PCB Parts Location.*

Table 2-3. Troubleshooting-Continued

MALFUNCTION	TEST OR INSPECTION	CORRECTIVE ACTION
	Step 4. Voltage Regulator Circuit on A1 PCB (fig. 2-7).	
	a. Using voltmeter, check for +15 to 17 VDC across C1.	Check Q1, Q2, and associated components. Replace defective component.
		<b>CAUTION</b>
		Use care when checking voltages and waveforms around the integrated circuits so adjacent leads are not shorted together. Catastrophic failure may result.
	b. Check for + 5 to 7 Vdc at U1-15.	Repair wiring.
	c. Check for +5 $\pm$ .2 Vdc between U1-8 (-) and U1-16 (+).	Check components associated with U1-16. Replace defective components/replace U1.
	d. Using voltmeter, check for +2.08 to 2.44 Vdc between U1-8 and U1-1.	Check components associated with U1-1 (and U1-16). Replace defective component/replace U1.
	e. Using voltmeter, check for +2.6 to 2.85 Vdc between U1-8 and U1-2.	Check components associated with U 1-2 (and U1-16). Replace defective component/replace U1.
	f. Using scope (1V/Div, DC), connect 1:1 probe between U1-7 and C1 (-). Adjust scope as required to observe display as shown in figure 2-7.	Check C3. replace C3 if defective/replace U1.
	g. Connect scope probe between U1-3 and C1(-). Adjust scope as required to observe display as shown in figure 2-7.	Check C2, replace C2 if defective/replace U1.
	h. Connect scope probe between U1-9 and C1 (-), observe dc level of 1.6 to 3.6 Vdc.	Check components associated with U1-9. Replace defective components/replace U1.

EL9AW016

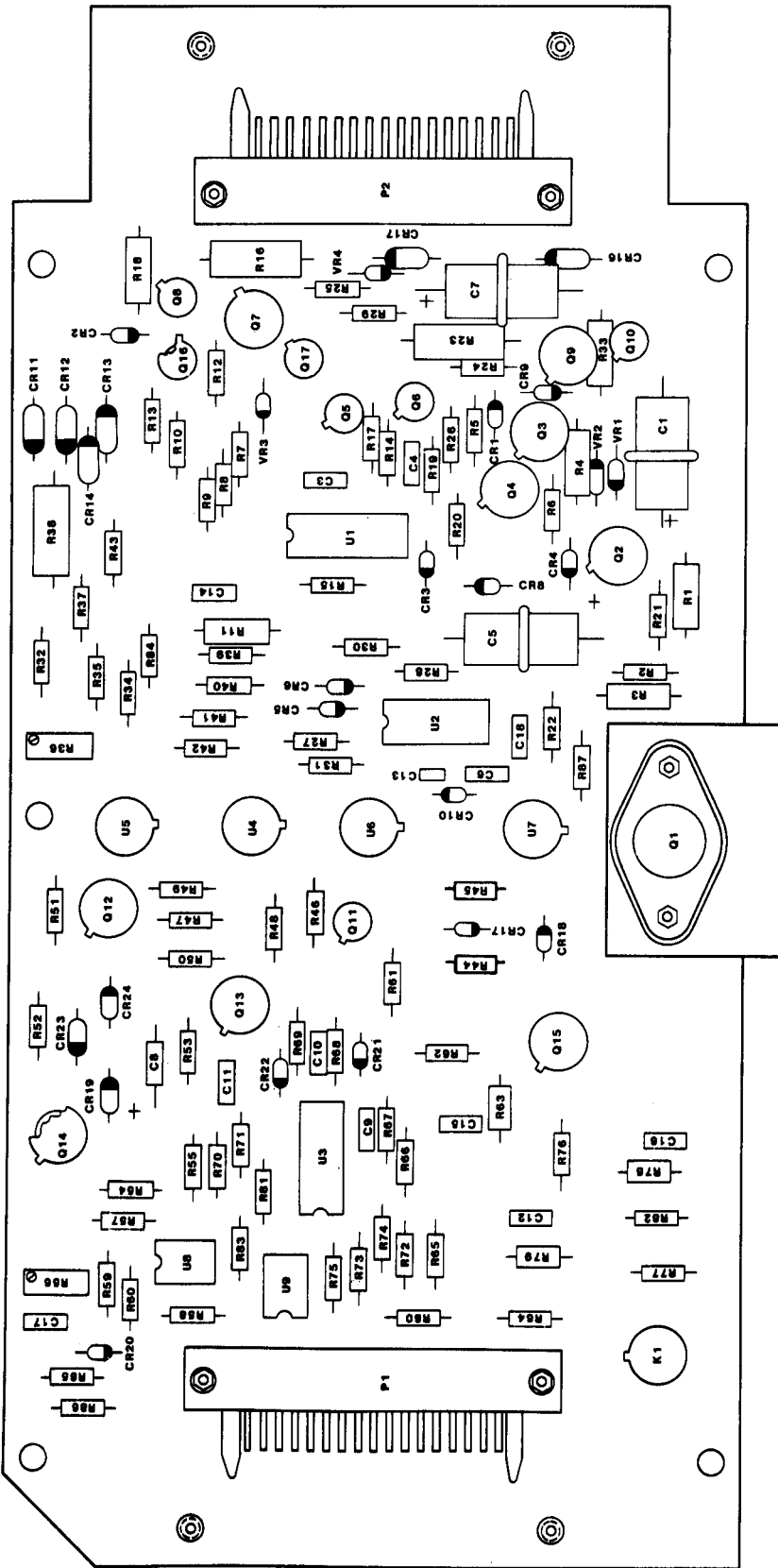
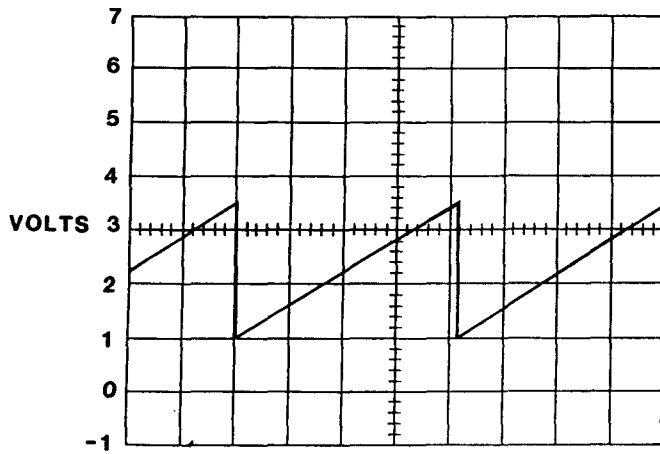
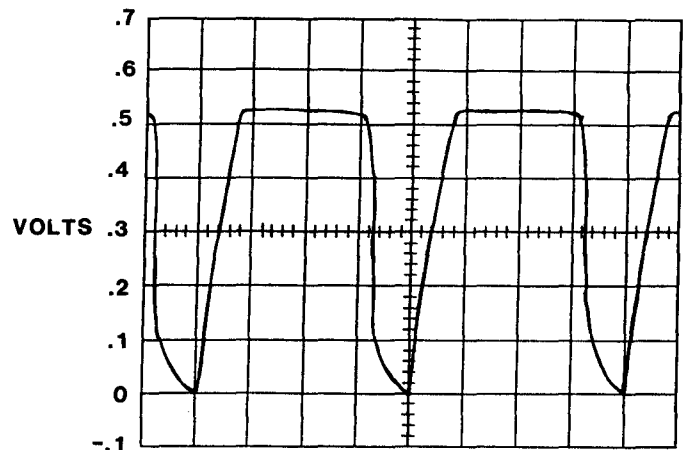

Figure 2-7. A1 PCB Parts Location.





TIME = 5 MICROSECONDS/DIVISIONS  
2-8(A)



TIME = 5 MICROSECONDS/DIVISIONS  
2-8(C)

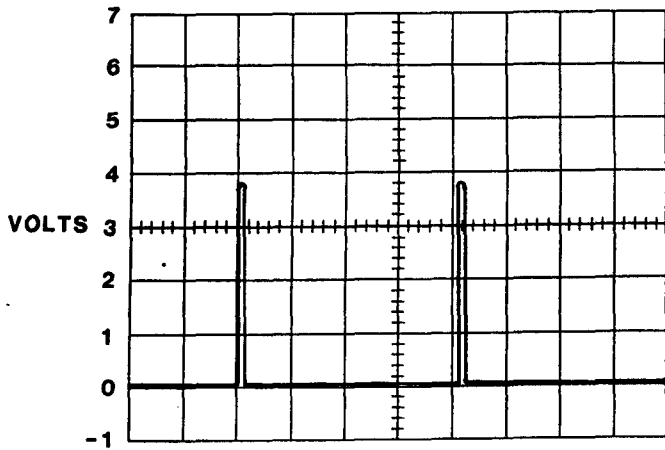

TIME = 5 MICROSECONDS/DIVISIONS  
2-8(B)

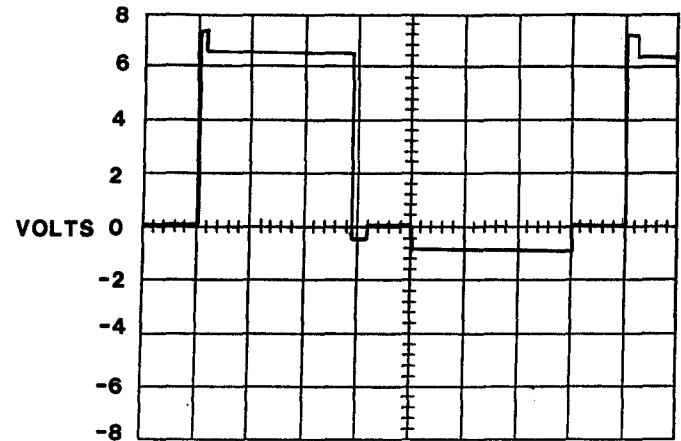

TIME = 5 MICROSECONDS/DIVISIONS  
2-8(D)

Figure 2-8(1), A1 PCB Waveforms (Sheet 1 of 2).

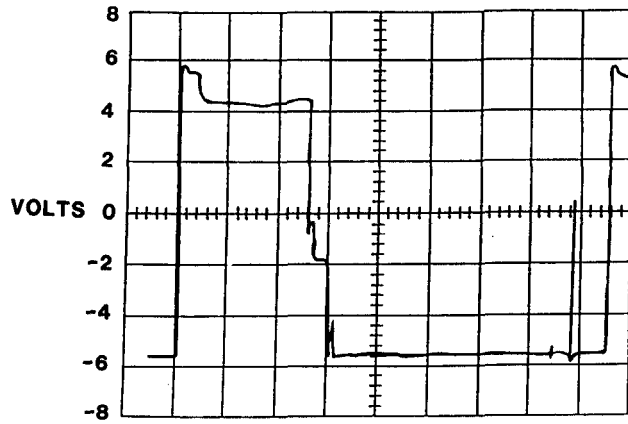

TIME = 5 MICROSECONDS/DIVISION  
2-8(E)

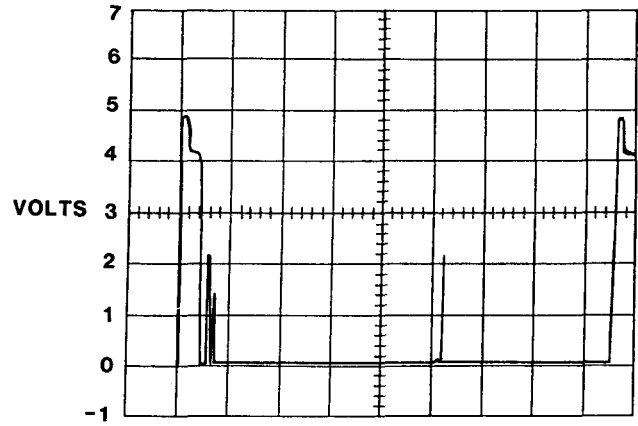

TIME = 5 MICROSECONDS/DIVISION  
2-8(G)

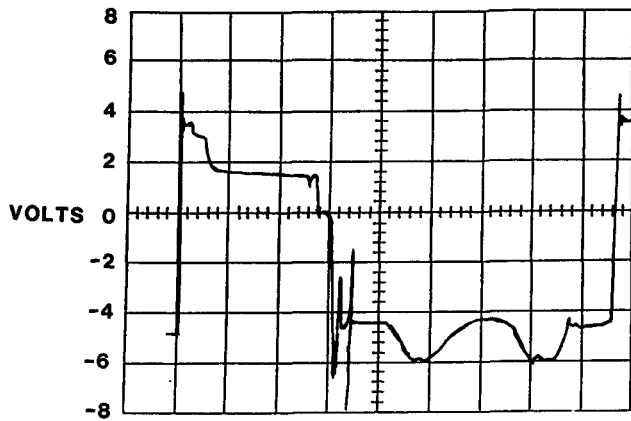

TIME = 5 MICROSECONDS/DIVISION  
2-8(F)

EL9AW018

Figure 2-8 ②. A1 PCB Waveforms (Sheet 2 of 2).

Table 2-3. Troubleshooting-Continued

MALFUNCTION	TEST OR INSPECTION	CORRECTIVE ACTION
	Step 5. Soft Start, Overvoltage + Current Limit Circuits (P/O A1 PCB) Check (fig. 2-6).	
	a. Using voltmeter, check for $+4 \pm 0.4$ Vdc between U2-9 and U2-12 (-), and +2.5 Vdc between U2-8 and U2-12 (-). Check components associated with soft start circuit/replace defective components.	
	b. Using scope (1V/Div), check for +0.8 to +0.9 Vdc between U2-6 and C1 (-) and $+2.5 \pm 0.1$ Vdc between U2-7 and C1 (-).	Check components associated with overvoltage circuit. Replace defective component. Adjust OV/UV potentiometer R56.
	c. Using scope (.1V/Div), connect 1:1 probe between U2-4 and C1 (-). Adjust scope as required to observe display as shown in figure 2-8C.	Turn OFF equipment and disconnect test cable. Using multimeter check continuity between E8 of A2 PCB to cathode of CR14 on A1 PCB and E9 of A2 PCB to anode of CR11 on A1 PCB. Check associated components on A1 and A2 PCB. Replace defective components.
	d. Using voltmeter, check for +0.35 to 0.85 Vdc between U2-5 and U2-12.	Check associated components. Replace defective component.
	Step 6. Drive Circuits From U1 to 20 KHz Switching Converter (P/O A1 PCB Check).	
	a. Using scope (2V/Div) connect 1:1 probe between U 1-11 and C 1 (-), and then between U1-11 and C1. Adjust scope as required to observe display as shown in figure 2-8D.	Check Q5, Q6, Q7, Q8, Q9, Q10, Q16, Q17, and associated components. Replace defective components.
	b. Connect scope probe between CR2 anode and C1 (-). Adjust scope as required to observe display as shown in figure 2-8E. Repeat procedure between CR9 anode and C1 (-).	Check associated drive circuit. Replace defective component.
	c. Connect scope probe between J2-4 and C1 (-). Adjust scope as required to observe display as shown in figure 2-8F. Repeat procedure between J2-11 and C1 (-).	Check associated drive circuit. Replace defective component.
	d. Connect scope (1V/Div) probe to Q8 collector (case) and scope ground to C7 (-). Adjust scope as required to observe display as shown in figure 2-8G. Repeat procedure between Q10 collector and C7 (-).	Check associated drive circuit. Replace defective component.
	e. Set variable load RANGE switch to 18A. Set load adjust for 2 A. Check for +5.1 to 5.6 Vdc between J1-5 (+) and J1-17 (-).	Repair wiring.
	Step 7. Undervoltage/Overvoltage Detection Circuits (P/O A1 PCB) Check.	
	a. Using voltmeter, check for +2.7 to 2.85 Vdc between U8-1 and U8-6.	Check associated components. Replace defective component/replace U8.
	b. Check for $+5.3 \pm 0.2$ Vdc across R60.	Turn OFF all equipment and remove test cable. Check wiring from J1-16 to rear panel P1-A6. Check C17, CR20, R59, R60, R85, R86, and U3. Repair wiring/replace defective component.
	c. Connect voltmeter between front panel +5V RTN (TP1) and +5V P1 (TP4). Loosen locking nut on +5V ADJ and slowly adjust potentiometer clockwise. Observe when voltmeter reading nears +6.1 to 6.5 Vdc, FAULT lamp lights, and voltmeter reading drops to less than +2 Vdc.	Check wiring from J1-15 to gate of Q7. Check C8, CR19, CR23, CR24, R51, R53, R54, R55, and U3. Repair wiring/replace defective component.
	d. Turn converter ON/OFF switch to OFF. Turn +5V potentiometer fully counterclockwise and turn converter ON/OFF switch to ON. Adjust +5V until voltmeter reads +4.9 to 5.1 Vdc. Remove voltmeter leads from TP1, TP4, and connect to C8 (-) and junction of R46, R47, and observe reading of +3.08 to 3.67 Vdc.	Check Q12, Q13, and associated components. Replace defective components.
	Step 8. Secondary Regulator Loop Circuit (P/O A1 PCB) Check.	
	a. Set variable load RANGE switch to 60A and adjust +5V potentiometer on front panel until voltmeter reads +4.98 to 5.02 Vdc and tighten locking nut. Connect voltmeter between U9-6 and U9-7 (+); observe indication of +3.047 to 3.121 Vdc.	Check U3, U9 and associated components. Replace defective component.
	b. Using voltmeter, check for +3.047 to 3.121 Vdc between U3-1 and U3-10 (+).	Check wiring from J1-12 on A1 PCB to P1-A4 on rear panel. Check U3-D and associated components. Replace defective component.
	c. Turn equipment OFF. Connect equipment as shown on figure 2-9. Connect the jumper between P2-A3 and P1-A3 on test cable. Connect a 0-1 amp power supply to P1-A6 and P1-A3 (+). Connect voltmeter to TP1 and TP4 on front panel. Turn ON input power supply and converter. Turn ON 0-1 amp power supply and adjust voltage until voltmeter reads +5.5 Vdc. Connect voltmeter between TP2 (+) and TP1 (-) on front panel, and observe reading of +5.069 to 5.192 Vdc.	Check U3B, Q15, and associated components. Replace defective component.

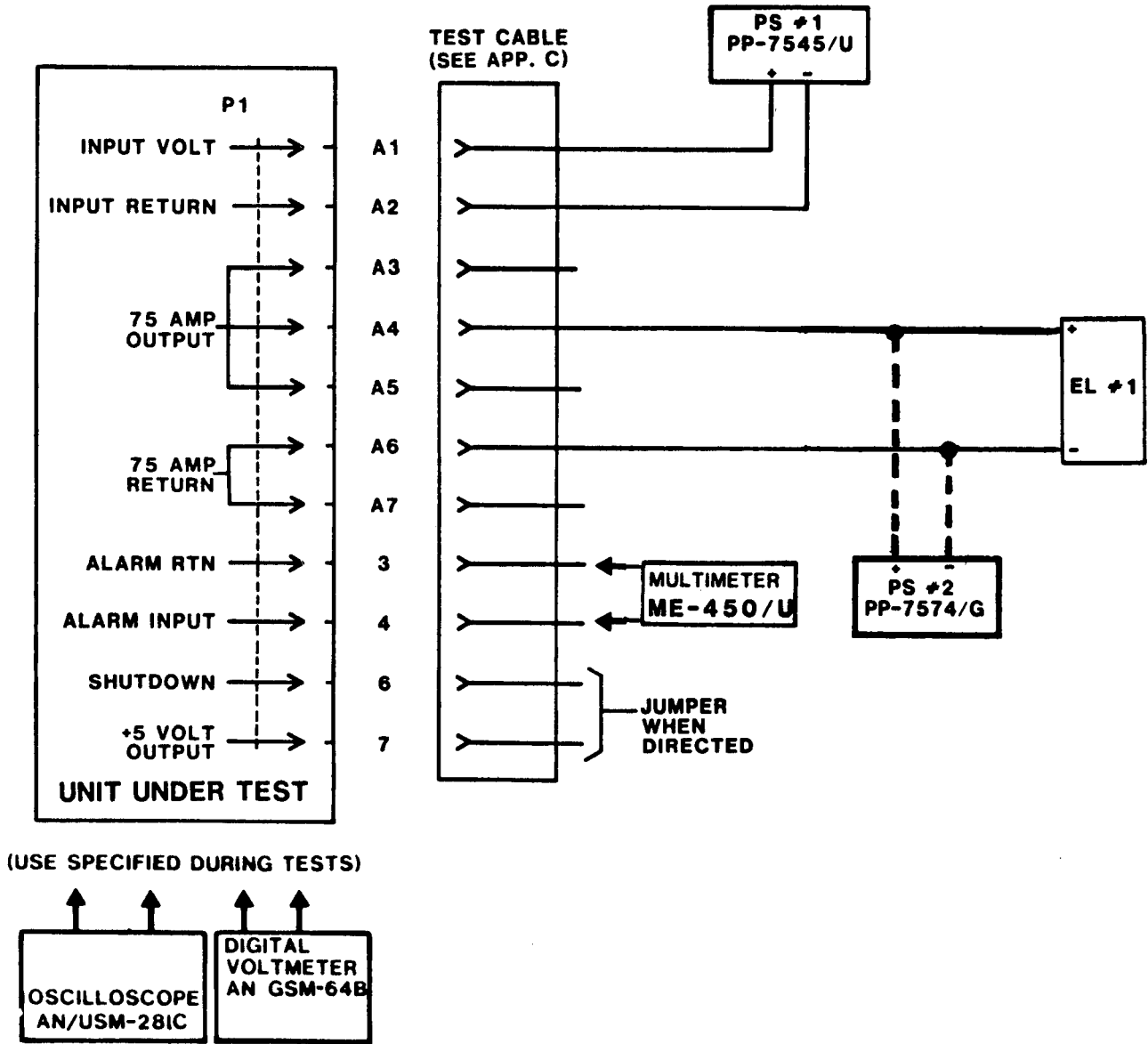

**EL9AW019**

Figure 2-9. Troubleshooting Setup #2.

Table 2-3. Troubleshooting-Continued

**MALFUNCTION**

TEST OR INSPECTION  
CORRECTION ACTION

- d. Turn equipment OFF. Connect voltmeter to TP1 and TP3 on front panel. Turn equipment ON and observe meter reading of +4.98 to 5.02 Vdc.  
Loosen locking nut on +5 VOLT ADJ (R8) and adjust it until meter reading is correct; then tighten locking nut.
- e. Using voltmeter, check for +3.047 to 3.121 Vdc between U3-5 (positive) and U3-11.  
Check U3 and associated components. Replace defective component.

Table 2-3. Troubleshooting-Continued

MALFUNCTION	TEST OR INSPECTION	CORRECTION ACTION
	<i>f.</i> Using multimeter, check for continuity between P1-3 and P1-4 on test cable.	Check wiring from P1 to S2. Check relay K1 and A1 PCB. Repair wiring/replace defective component.
	<i>g.</i> Remove locking plate and set system selector switch to AN/TTC-38. Using multimeter, check for +4.9 to 5.5 Vdc at P1-3 and P1-4 leads on test cable.	Check wiring from P1 to A1 PCB. Check S2. Repair wiring/replace defective component.
	<i>h.</i> Set system selector switch S2 to AN/TYC-39; replace locking plate and hardware. Set multimeter for resistance measurement and connect to P1-3 and P1-4 on test cable. Connect voltmeter to TP1 and TP4 on front panel. Set variable load RANGE switch to 180A and increase current loading until voltage on voltmeter decreases. Observe that FAULT lamp is lighted and multimeter indicates open circuit. Voltmeter reading should be +2.5 to 4.75 Vdc.	Check wiring from S1 to J2-3 on A1 PCB. Check Q3, Q4, and associated circuitry (voltage regulator check). Check Q11, U7, and associated circuitry ((UV/OV) detection circuit). Repair wiring/replace defective component.
	<i>i.</i> Adjust variable load to 75A, and momentarily push in short circuit button. Observe current of 10 to 45A on meter of variable load. Upon release of short circuit button, observe voltmeter reading of +4.9 to 5.1 Vdc, and 75A indication on meter of variable load.	Check U2, U4, Q11, and associated components. Check T1 on A2 PCB. Replace defective component.

## Section III. MAINTENANCE PROCEDURES

### 2-6. Maintenance Functions

General support maintenance includes all the procedures listed in the maintenance allocation chart (MAC) and instructions applicable to testing, evaluating and determining the serviceability of the converter. When lower level maintenance reports a fault, general support will verify the fault and determine the extent of testing, repair, modification, or replacement necessary to make the equipment serviceable.

### 2-7. Preliminary Maintenance Procedures

*a. Operational Check.* After repairs have been made to the converter, it should be ready for return to service. To verify its condition, refer to section IV of this chapter.

*b. Inspection of Installed Items.* Inspection includes, but is not limited to the following:

(1) *Preliminary inspection.*

(a) A check of maintenance forms and records attached to the equipment.

(b) A check of DA Pam 310-1 for any modification work order (MWO) pertaining to the converter.

(c) A visual inspection of the converter for compliance with all MWO'S.

(d) A listing of outstanding MWO'S on DA Form 2404.

(2) *Visual inspection.*

(a) *Exterior surfaces.* Inspect exterior surfaces for obvious signs of damage. Check metal surfaces for signs of rust and corrosion.

(b) *Interior surfaces.* Inspect for broken connections, improperly seated semiconductors, damaged or improperly installed circuit boards and heat-damaged parts.

### 2-8. Cleaning

#### NOTE

Do not perform needless disassembly of equipment for the purpose of cleaning. Clean the equipment only to the extent required for serviceability.

*a. Exterior Surfaces.*

(1) Remove loose dirt or dust from outside surfaces of case and front panel using lint-free cloth (item 5, appx B) and/or soft bristled brush (item 2, appx B).

#### WARNING

Adequate ventilation should be provided while using TRICHLOROTRIFLUOROETHANE. Prolonged breathing of vapor should be avoided. The solvent should not be used near heat or open flame; the products of decomposition are toxic and irritating. Since TRICHLOROTRIFLUOROETHANE dissolves natural oils, prolonged contact should be avoided. When necessary, use gloves which the solvent cannot penetrate. If the solvent is taken internally, consult a physician immediately.

(2) Remove ground-in dirt or grease using lint-free cloth (item 5, appx B) dampened (not wet) with cleaning compound (item 6, appx B).

(3) Rinse cleaned areas with clean water and allow to dry.

*b. Blower Screen.* Remove dust and dirt from screen using soft bristled brush (item 2, appx B).

*c. Interior Surfaces.*

**WARNING**

Compressed air shall not be used for cleaning purposes except where reduced to less than 29 pounds per square inch (psi) and then only with effective chip guarding and personnel protective equipment. Do not use compressed air to dry parts when TRICHLOROTRIFLUOROETHANE has been used. Compressed air is dangerous and can cause serious bodily harm if protective means or methods are not observed to prevent chips or particles (of whatever size) from being blown into the eyes or unbroken skin of the operator or other personnel.

**CAUTION**

Air jet can damage delicate components. Be careful NOT to place air jet too close to small coils or delicate components.

**NOTE**

When necessary to disturb the position of wiring and harness assemblies for cleaning purposes, always replace them to their original position after cleaning.

(1) Remove dust, dirt, and foreign matter from all surfaces, components, and wiring using air jet and soft bristled brush (item 2, appx B).

(2) Remove dust from connector holes and recesses using air jet and soft bristled brush.

**CAUTION**

Use care when using lint-free cloth to wipe cleaning compound from resistors, as making colors may be removed.

(3) Wipe interior surfaces using lint-free cloth, dampened (not wet) with cleaning compound (item 6, appx B).

(4) Dry surfaces immediately with lint-free cloth.

(5) Wipe dust and dirt from casings, pins and cable clamps using lint-free cloth dampened (not wet) with cleaning compound.

(6) Dry surfaces immediately with lint-free cloth.

**2-9. Removal and Replacement**

(fig. 2-10)

Procedures listed are for removable modules, components, and assemblies as specified in the Maintenance Allocation Chart (MAC), TM 11-6130-429-12. Most parts and assemblies of the converter can be reached easily without the use of special tools or instructions. Replacement, however; may require special techniques to assure proper operation. Tag all wires to be unsoldered, so as to avoid error when reconnecting.

**WARNING**

Do not attempt any unauthorized repairs on this equipment. Avoid personal injury- BE SAFE. Observe all cautions listed in the front of this manual.

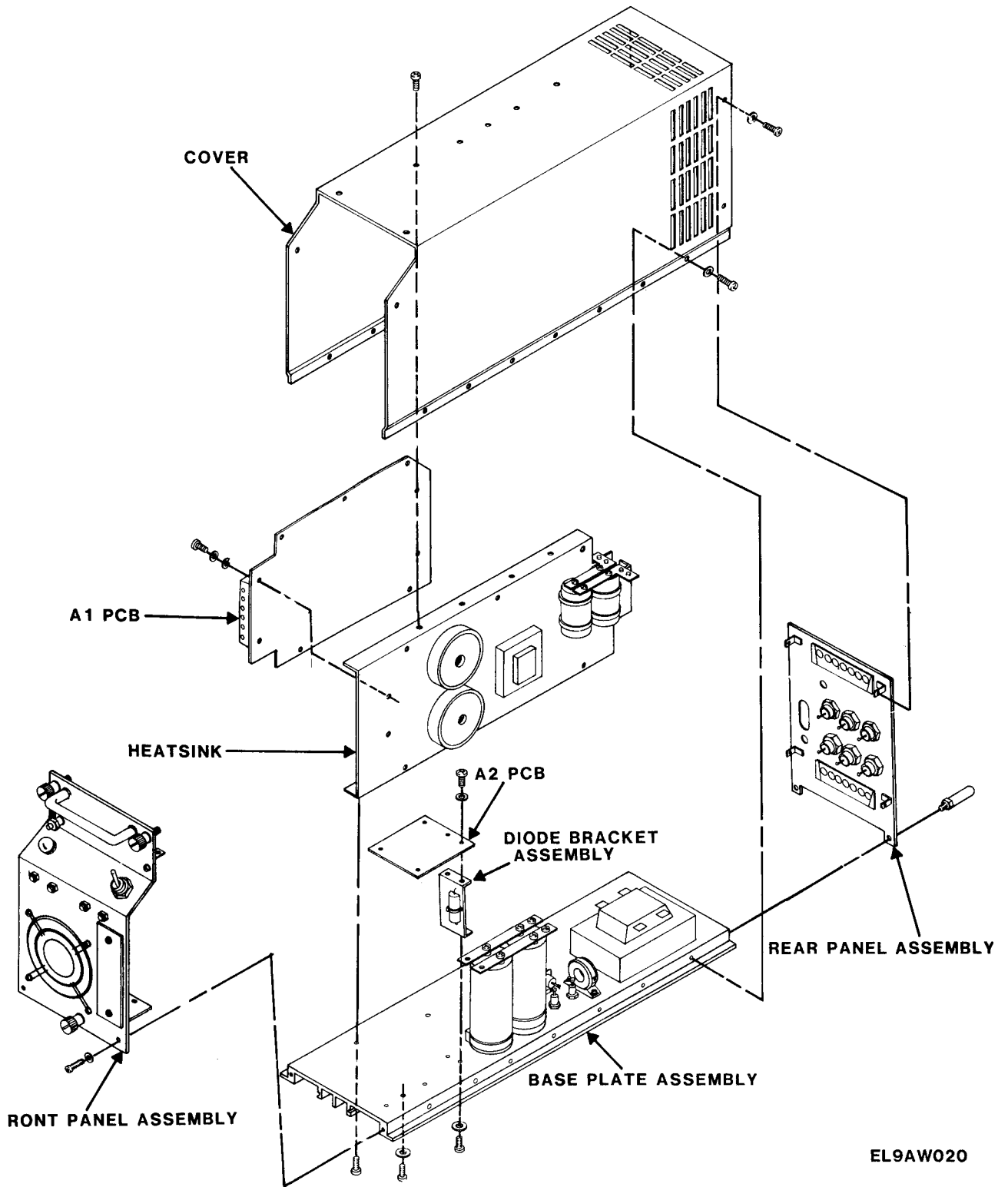

EL9AW020

Figure 2-10. Converter CV-3734/T Exploded View.

*a. Cover Removal and Replacement (fig. 2-10).*

(1) *Removal.*

(a) Remove five top screws.

(b) Remove six left screws and six right side screws.

(c) Lift off cover.

(2) *Replacement.*

(a) Ensure heatsink has a thin coating of thermal compound.

(b) Position cover over converter.

(c) Install six right side screws, six left side screws, and tighten.

(d) Install five top screws and tighten.

*b. Front Panel Removal and Replacement (fig. 2-10).*

(1) *Removal.*

(a) Remove two screws and washers.

(b) Place converter on side, remove two hex nuts, lockwashers, flatwashers, and panhead screws securing gusset.

(c) Swing front panel up, tag and unsolder all leads, remove front panel.

(2) *Replacement.*

(a) Position front panel in place, solder all leads to their respective terminals.

(b) Replace two panhead screws, flatwashers, lockwashers, and nuts.

(c) Replace two screws and washers.

*c. Rear Panel Removal and Replacement (fig. 2-10).*

(1) *Removal.*

(a) Remove two guide pins, tag and unsolder all leads.

(b) Remove rear panel.

(2) *Replacement.*

(a) Position rear panel in place. Solder all leads to their respective terminals.

(b) Replace two guide pins and tighten.

*d. Heatsink Removal and Replacement (fig. 2-10).*

(1) *Removal.*

(a) Remove printed circuit board A1 (para 2-9e.)

(b) Remove rear panel (para *c* above).

(c) Remove two screws, flatwashers and move wire harness with cable clamps aside.

(d) Remove sets of two screws and four screws, respectively.

(2) *Replacement.*

(a) Ensure heatsink has a thin coating of thermal compound on bottom.

(b) Slide heatsink straight in and aline with mounting holes.

(c) Replace sets of four screws and two screws.

(d) Aline cable clamps, replace two flatwashers and two screws and tighten.

(e) Replace A1 (para 2-9e).

(f) Replace rear panel (para 2-9c) above.

*e. Printed Circuit Board A1 Removal and Replacement (fig. 2-10).*

(1) *Removal.*

(a) Remove two screws, lockwashers, flatwashers, and clamps.

(b) Disconnect J1 from P1.

(c) Remove two screws, lockwashers, flatwashers, and clamps.

(d) Disconnect J2 from P2.

(e) Remove two small flathead screws.

(f) Remove five screws, lockwashers, and flatwashers.

(g) Remove A1.

(2) *Replacement.*

(a) Install A1 by lining up.

(b) Install five flatwashers, lockwashers, screws, and tighten.

(c) Install two screws and tighten.

(d) Connect P2 to J2.

(e) Install two clamps, flatwashers, lockwashers, screws and tighten.

(f) Connect P1 to J1.

(g) Install two clamps, flatwashers, lockwashers, screws and tighten.

*f. Printed Circuit Board A2 Removal and Replacement (fig. 2-10).*

(1) *Removal.*

(a) If necessary to remove A2 PCB, refer to the schematic (fig. FO-2); then tag and unsolder leads.

(b) Remove three screws and flatwashers.

(c) Remove two screws, flatwashers, and move wire harness with clamps aside.

(d) Remove protective coating at wire lead connections of A2.

(2) *Replacement.*

(a) Install A2 and aline mounting holes.

(b) Aline cable clamps, install two flatwashers, screws, and tighten.

(c) Install three flatwashers, screws, and tighten.

(d) Solder leads to printed wiring conductor.

*g. Baseplate Removal and Replacement (fig. 2-10).*

(1) *Removal.*

(a) Remove front panel (para 2-9b above).

(b) Remove rear panel (para 2-9c above).

(c) Set converter upside down on bench with front panel hanging over.

(d) Remove heatsink (para 2-9d above).

(f) Lift off baseplate.

(2) *Replacement.*

(a) Aline baseplate over A1P1.

(c) Replace heatsink (para 2-9d above).

(d) Replace rear panel (para 2-9c above).

(e) Replace front panel (para 2-9b above).



**2-10. Disassembly and Reassembly****NOTE**

Before any part is removed, note the position of the part and its leads. Wire replacements in essentially the same position to avoid undesired coupling or shorting together of wires. If necessary, use tags.

- a. *Disassembly of Front Panel* (fig. 2-11).

**NOTE**

Front panel removal is NOT required for removal and replacement of the ON/OFF Switch (S1), VOLT ADJ potentiometers (R1) and Test Points TP1 (+5 MON), TP4 (RTN). All other repairs require removal of front panel assembly from the main chassis.

- (1) *Blower (B1)*.

(a) Remove hex nut, lockwasher, flatwasher, clamp retainer, cable clamp, flatwasher, and screw.

(b) Remove four hex nuts, four lockwashers, four flatwashers, finger guard, four flatwashers and

four screws.

(c) Disconnect wires from screw terminals and remove defective blower B1.

(d) Install replacement blower and secure with four screws, flatwashers, finger guard, four flatwashers, lockwashers, hex nuts.

(e) Connect wires to screw terminals and tighten.

(f) Replace screw with flatwasher, cable clamp, clamp retainer, flatwasher, lockwasher, hex nut and tighten.

- (2) *Test points*.

**NOTE**

Test points can be replaced without removing the front panel.

(a) Unsolder wire from defective test point.

(b) Remove hex nut, lockwasher, and defective test point.

(c) Install replacement test point, lockwasher, hex nut, and tighten.

(d) Solder wire to replacement test point.

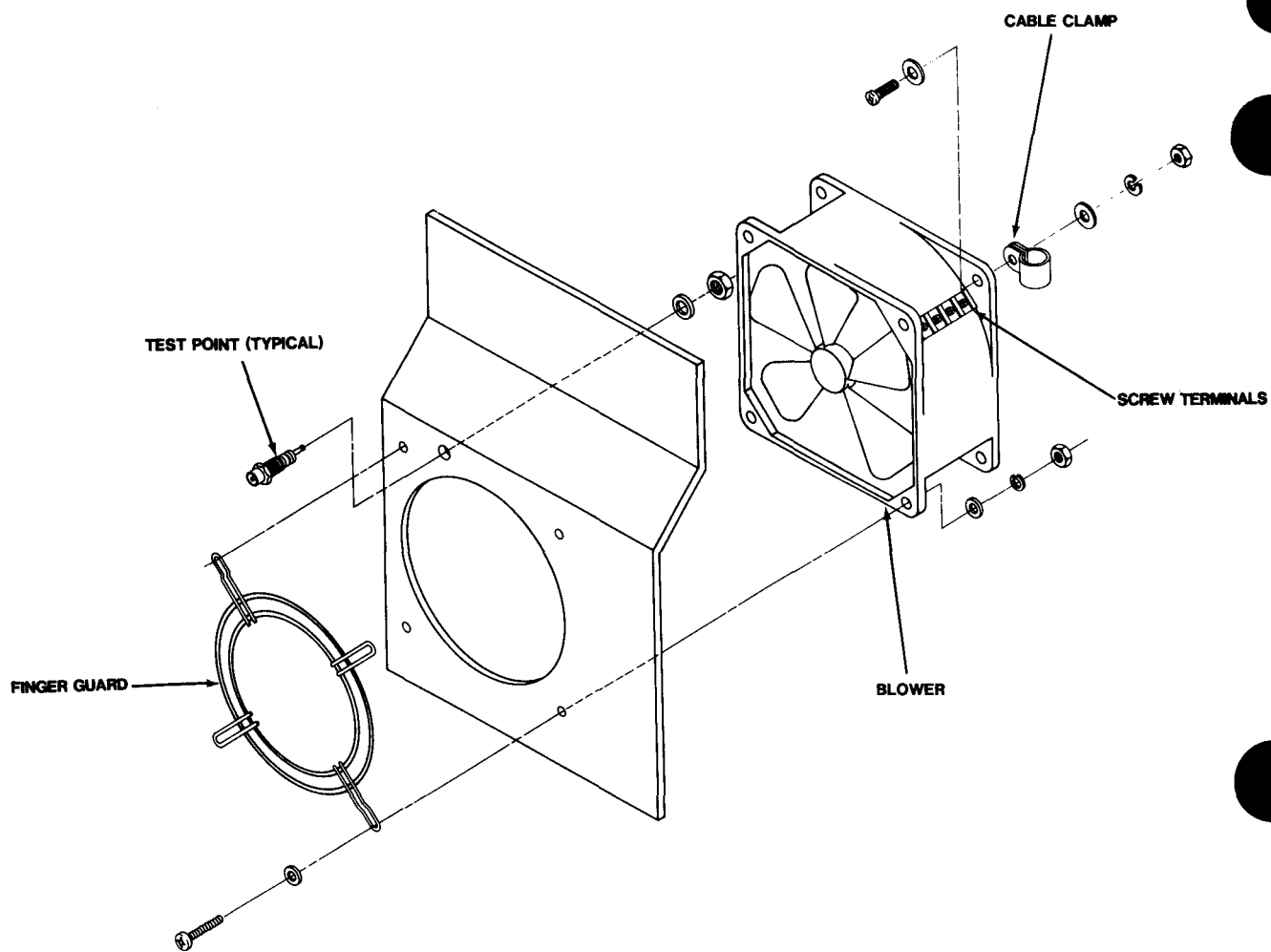

**EL9AW021**

Figure 2-11. ① .Front Panel Disassembly (Sheet 1 of 2).

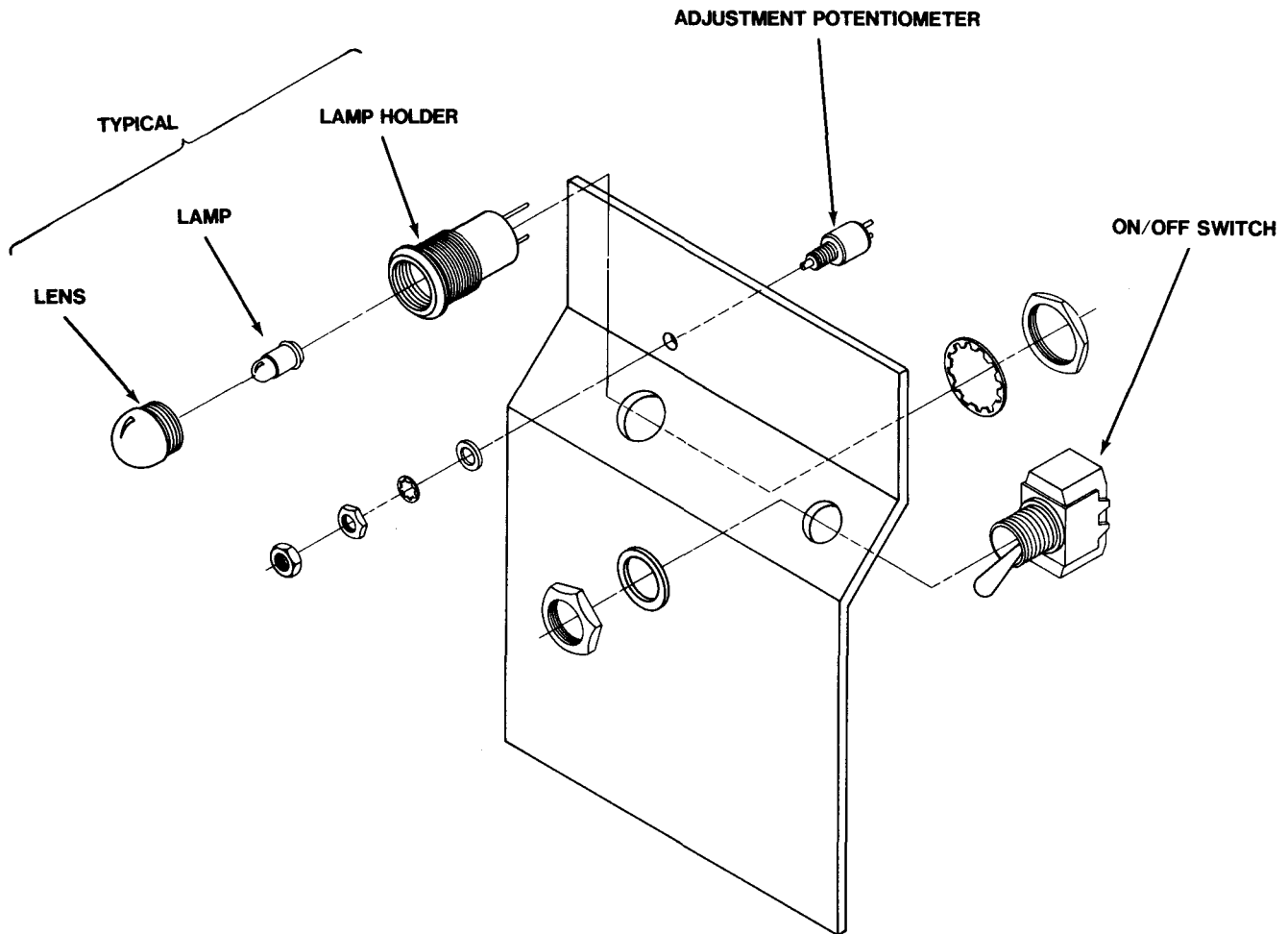

Figure 2-11 (2).. Front Panel Disassembly (Sheet 2 of 2).

(3) Fault Lampholder (XDS1).

- (a) Unscrew lens cap and remove bulb.
- (b) Tag and unsolder wires from defective lampholder.
- (c) Remove hex nut, lockwasher, and defective lampholder.
- (d) Install replacement lampholder, lockwasher, hex nut, and tighten.
- (e) Solder wires to replacement lampholder.
- (f) Install bulb and replace lens cap.

(4) ON/OFF switch (S1).

- (a) Tag and unsolder wires from defective switch.
- (b) Remove hex nut, flatwasher, and defective switch.
- (c) Install new switch, flatwasher, hex nut and tighten.
- (d) Solder wires to replacement switch.

(5) Voltage adjust resistor (R8).

- (a) tag and unsolder wires from defective resistor.
  - (b) Remove lock nut, hex nut, lockwasher, flatwasher, and defective resistor.
  - (c) Install flatwasher, lockwasher, hex nut, and tighten.
  - (d) Solder wires to replacement resistor (R8).
- b. Disassembly of Rear Panel (fig. 2-12).

**NOTE**

Rear panel disassembly is NOT required for repair.

(1) Connector plugs P1, P2.

- (a) Remove two screws, lockwashers, and flatwashers.
- (b) Unsolder and remove capacitors.

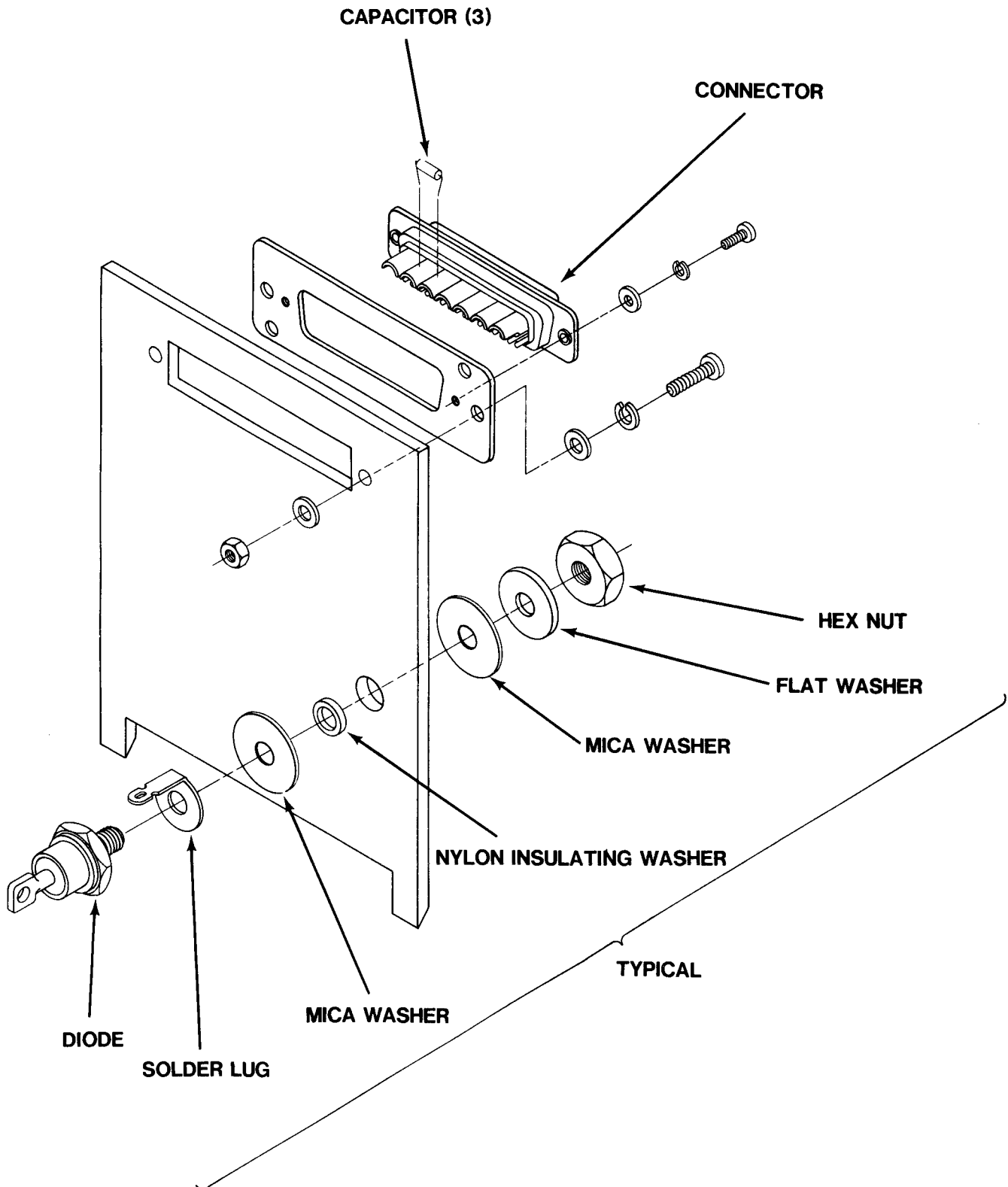

**EL9AW023**

Figure 2-12. Rear Panel Disassembly.

**NOTE**

C19 is located on P1 and C20 is located on P2.

(c) Tag and unsolder all wires from defective connector.

(d) Remove defective connector.

(e) Solder capacitors to replacement connector.

(f) Solder all wires to replacement connector.

(g) Install replacement connector in rear panel and secure with two flatwashers, lockwashers and screws.

(2) *Diodes CR12 through CR15, CR20 and CR21*

(a) Unsolder leads from cathode of diode.

(b) Remove liquid staking from hex nut of defective diode (if applicable).

(c) Remove hex nut, flatwasher, and mica insulating washer.

(d) Remove defective diode from rear panel.

(e) Remove nylon insulating washer from diode mounting hole.

(f) Pull solder lug slightly away from rear panel and remove mica insulating washer.

(g) Inspect both mica insulating washers for holes and cracks.

(h) If they both are good, install one between solder lug and rear panel.

(i) Line up holes and press the solder lug back into position against the rear panel.

(j) Install nylon insulating washer in rear panel.

(k) Install new diode in rear panel.

(l) Replace mica insulating washer, flatwasher, hex nut, tighten and torque to 25 inch-pounds.

(m) Solder leads to cathode of diode.

(n) Apply liquid staking to hex nut (if applicable).

c. *Disassembly of Heatsink.*

**NOTE**

Heatsink removal is NOT required replacement of all parts.

(1) *Capacitors C14 and C15.*

**NOTE**

Tag wire terminal lugs where applicable.

(a) Remove two screws, lockwashers, and flatwashers.

(b) Remove defective capacitor by cutting two cable ties.

(c) Insert two new cable ties through their mounting holes.

**WARNING**

Positive (+) terminal of capacitor MUST be connected to + bus bars. Serious injury

to personnel and damage to equipment will occur if correct polarity connections are not made.

**NOTE**

C14, C15 + bus bar is nearest to rear panel.

(d) Install new capacitor with + terminal to + bus.

(e) Replace any terminal lugs removed and secure with two flatwashers, lockwashers, and screws.

(f) Tighten both cable ties around capacitor and remove any excess.

(2) *Capacitors, diodes, and resistors.*

(a) Unsolder and remove defective part, noting polarity marks where applicable.

(b) Solder replacement part in proper position.

**CAUTION**

C16 positive must be connected to gate of Q7 for proper operation.

(3) *Inductor L4.*

(a) Tag and unsolder leads going through inductor. Remove defective inductor from spring clip mounting.

(b) Insert replacement inductor over wires and mount in spring clip mounting.

(c) Solder leads in their proper position.

(4) *Thyristor Q7.*

(a) Tag Q7 leads, remove with capacitor C16 and resistor R9.

(b) Remove liquid staking from hex nut.

(c) Remove hex nut, flatwasher, large insulating washer, and small insulating washer.

(d) Slowly remove defective Q7, allowing large insulating washer to drop out and carefully set solder lug aside so lead connection is not damaged.

(e) Inspect both large insulating washers for holes or cracks. If they both are good, save for reassembly.

(f) Ensure that large insulating washers have a small amount of thermal paste applied evenly to both sides.

(g) Insert replacement Q7 through solder lug, large insulating washer, and heatsink.

(h) Install small insulating washer, large insulating washer, flatwasher, hex nut and finger tighten.

(i) Aline Q7 and solder lug to original position, tighten and torque hex nut to 25 inch-pounds.

(j) Install and solder Q7 leads, capacitor C16 and resistor R9.

(k) Apply liquid staking to hex nut.

(5) *Switch S2.*

(a) Tag and disconnect all leads from defective switch.

(b) Remove hex nut, lockwasher, flatwasher, and defective switch.

(c) Install replacement switch, flatwasher, lockwasher and hex nut.

(d) Aline switch in position and tighten hex nut.

(e) Solder all leads to replacement switch.

(6) *Transistors Q1 through Q6.*

(a) Slide sleeving up base and emitter wires, tag wires, and unsolder.

(b) Remove two hex nuts and lockwashers.

(c) Holding transistor in place, remove two screws and one flatwasher.

(d) Carefully remove Q assembly.

#### CAUTION

When removing insulator shield, be careful not to break wire connection.

(e) Carefully remove rubber insulating washer, insulator shield, and rubber insulating washer from transistor.

(f) Inspect rubber insulating washers for holes or cracks. If they are good, save for reassembly.

(g) Aline and install replacement transistor into rubber insulating washer, insulator shield, and rubber insulating washer.

#### CAUTION

Although not removed, solder lug, two insulating shoulder washers, and two small insulating washers must be in position before replacement transistor is installed.

(h) Ensure that solder lug, two insulating shoulder washers, and two small insulating washers are in position.

(i) Install Q assembly on heatsink and hold in place.

(j) Install one flatwasher and two screws.

(k) Install two lockwashers, hex nuts, tighten and torque to 9 inch-pounds.

(7) *Diodes CR6 through CR11.*

(a) Unsolder lead from defective diode.

(b) Remove hex nut and flatwasher.

(c) Pull solder lug slightly away from heatsink.

(d) Slowly remove defective diode and allow mica insulating washer to drop out.

(e) Pull solder lug slightly away from heatsink.

(f) Continue to remove defective diode and allow nylon insulator and mica insulating washer to drop out.

(g) Completely remove defective diode.

(h) Inspect mica insulating washers; make sure they have a small amount of thermal compound applied evenly to both sides.

(i) Insert replacement diode through solder lug, install mica insulating washer, nylon insulator

and second mica insulating washer through solder lug.

(i) Install flatwasher and hex nut and finger tighten.

(k) Aline diode to original position; tighten and torque to 25 inch-pounds.

(l) Solder connection to diode lead; apply liquid staking to hex nut.

(m) Replace A1 PCB (para 2-9e).

d. *Disassembly of Baseplate.*

#### NOTE

Baseplate removal is NOT required for replacement of components.

(1) *Capacitors C1 and C2.*

(a) Unsolder and remove defective part.

(b) Install replacement part in proper position and solder.

(2) *Capacitors C4 and C5.*

(a) Loosen screw, lockwasher, and nut of defective capacitor.

(b) Remove four screws, lockwashers and flatwashers.

(c) Move aside bus and remove defective capacitor.

#### WARNING

Positive (+) terminals of C4 and C5 must be connected with + bus.

(d) Install replacement capacitor with positive (+) terminal to + bus.

(e) Aline bus over capacitor.

(f) Install four flatwashers, lockwashers, screws and tighten.

(g) Tighten nut, lockwasher, and screw.

(3) *Diode CR1.*

(a) Unsolder connection from diode lead.

(b) Remove hex nut, flatwasher, mica insulating washer, and nylon washer.

(c) Remove defective CR1; allow mica insulating washer and solder lug to drop.

(d) Inspect mica insulating washers for holes or cracks. If they are good, save for reassembly.

(e) Make sure that mica insulating washers have a small amount of thermal compound applied evenly to both sides.

(f) Insert replacement CR1 through solder lug, mica insulating washer and bracket.

(g) Install nylon washer, mica insulating washer, flatwasher, hex nut and finger tighten.

(h) Aline diode and solder lug to original position; tighten and torque hex nut to 25 inch-pounds.

(i) Solder connection to diode lead.

(4) *Inductor L1.*

(a) Tag and unsolder leads from defective L1.

(b) Remove four screws and lockwashers.

(c) Aline replacement L1 and secure with four screws and lockwashers.

(d) Solder leads to replacement L1.

(5) *Inductor L2.*

(a) Tag and unsolder leads going through inductor; remove defective inductor from spring clip mounting.

(b) Insert replacement inductor over wires and mount in spring clip mounting.

(c) Solder leads in their proper position.

(6) *Inductor L3.*

(a) Tag and unsolder leads from defective L3.

(b) Remove four screws and defective L3.

(c) Aline replacement L3 and secure with four screws.

(d) Solder leads to replacement L3.

(7) *Transformers T1 and T2.*

(a) Remove A1 (para 2-9e).

(b) Remove A2 (para 2-9f), but do not unsolder lead connections.

(c) Remove hex nut, lockwasher, flatwasher, nylon insulating washer and rubber insulating washer.

(d) Remove transformer.

**CAUTION**

Although not removed, large rubber insulating washer and flat head screw must be in position before replacement transformer is installed.

(e) Remove flatwasher and screw from transformer.

(f) Install screw and flatwasher into replacement transformer. Insert into heatsink.

(g) Install rubber insulating washer, nylon insulating washer, flatwasher, lockwasher, hex nut, and tighten.

(h) Solder all leads to their proper connections.

(i) Replace A2 (para 2-9e).

(j) Replace A1 (para 2-9f).

**2-11. Printed Circuit Board Repair**

a. *Printed Circuit Wiring Repair.* Repair printed wiring that has a crack, pinhole, cut or notch more than 30 percent of the wires width as follows:

(1) Remove protective coating.

(2) Place a short length of flat bus wire over the defective wiring.

**CAUTION**

Use a pencil-type soldering iron with a 25-watt maximum rating. Too much heat from the iron will damage the printed wiring of circuit boards.

(3) Solder the entire length of bus wire to the printed circuit wiring.

(4) Apply a protective coating to the exposed area after completing repairs.

b. *Component Parts.* To remove defective parts:

(1) Cut leads as close as possible between part and circuit board mounting holes.

(2) Remove protective coating around lead connections on the boards printed wiring side.

(3) Heat printed wiring at mounting holes until solder melts.

(4) Bend the leads of replacement part to fit mounting holes.

**NOTE**

Transistors must have mounting pads on them before inserting into circuit board.

(5) Insert leads through mounting holes from parts side of circuit board.

(6) Press part firmly against board.

(7) On circuit boards wiring side, cut leads leaving 1/8 inch protruding.

(8) Bend and press the leads against the printed wiring.

(9) Quickly solder leads to printed wiring conductor.

(10) Apply a protective coating to all repaired exposed areas.

c. *A1 PCB Connector P1 and P2 Replacement.*

(1) Remove liquid staking from two hex nuts.

(2) Remove two hex nuts, four flatwasher, and two screws.

(3) When removing defective connector, cut all pin leads as close as possible between connector and circuit board mounting holes.

(4) Remove protective coating around lead connections on the circuit boards printed wiring side.

(5) Heat printed wiring at mounting holes with iron until solder melts.

(6) Remove excess solder and remaining pieces of leads.

(7) Ensure lead mounting holes are free of solder.

(8) Aline connector insert leads through mounting holes from parts side of circuit board.

(9) Press connector firmly against board, ensuring connector is flat.

(10) Install two screws, four flatwashers, two hex nuts, and tighten.

(11) Bend and press the lead against the printed wiring.

(12) Quickly solder leads to printed wiring conductor.

(13) Cut off any lead excess over 1/16 inch.

(14) Apply liquid staking to two hex nuts and then apply protective coating to all repaired exposed areas.

**2-12. Painting**

The converter is painted in accordance with military specification MIL-F-14072, Finish No. E513, (item 9, appx B). Use this material if the entire cover is stripped and refinished. For nicks, scratches, or small areas, use any matching paint or finish listed in SB 11-573.

**NOTE**

Touchup painting is recommended instead of refinishing whenever practical; screw heads, test points, and other mounted parts should not be painted or polished with abrasives. Apply touchup or new finish in accordance with TB 43-0118.

**Section IV. TEST PROCEDURES**

**2-13. General**

The following test procedures ascertain that all maintenance functions contained in this manual have been compiled with before the equipment is returned to the using organization, or placed in storage.

*a. Modification Work Orders.* Check to see whether any MWO'S are required for the converter or its components. Check equipment to see if applicable MWO'S have been applied and MWO number is stamped as required. Perform modification or request for modification as applicable.

*b. Final Performance Tests.* The components of the converter shall meet the requirements of table 2-2 to insure correct functional operation.

(1) *Test equipment and materials.* Required test equipment is listed in paragraph 2-2.

(2) *Test connections and conditions.* The test connections and conditions are listed in paragraph (3) below.

(3) *Test procedures.* Perform the bench test, after any repair, and before qualifying equipment for field use.

Operational Test	Table 2-1
Bench Test	Table 2-2
Troubleshooting	Table 2-3
Physical Test and Inspections	Table 2-4

**2-14. Physical Test and Inspections**

*a. Test Equipment.* None required.

*b. Test Connections and Conditions.*

(1) No connections are necessary.

(2) Following conditions are necessary.

*(a) Remove top cover.*

*(b) Subassemblies:* Inspect at time of disassembly and/or repair.

*c. Procedure.* Inspect as specified in table 2-4.

*Table 2-4. Physical Test and Inspection*

Test	Indication
Inspect chassis, cover, front and rear panels for physical damage such as dents, punctures or bent areas.	There should be no physical damage serious enough to prevent proper operation.
Inspect switches, connectors, terminal boards, printed circuit cards, and lamp for damage or missing parts.	There should be no missing parts or damage so as to prevent proper operation.
Inspect components for condition of finish and identification markings.	There should be no bare metal showing on painted surfaces. Identification marking should be legible.
Inspect components for loose, damaged or missing hardware.	There should be no loose, damaged or missing hardware.
Inspect cables and wiring for fraying, cuts or breaks in insulation.	There should be no fraying, cuts or breaks in insulation.
Inspect solder connections for excessive, skimpy, or cold solder joints.	There should be no excessive, skimpy, or cold solder joints.
Check ON/OFF and SYSTEM SELECT switches for proper operation.	All switches should operate freely without binding.
Check BLOWER for proper operation by rotating blades.	Fan blades should rotate freely without binding and have adequate clearance.



# APPENDIX A

## REFERENCES

---

### A-1. Scope

This appendix lists all forms, field manuals, technical manuals and miscellaneous publications referenced in this manual.

### A-2. Forms

Equipment Inspection and Maintenance Worksheet	DA Form 2404
Discrepancy in Shipment Report (DISREP)	SF 361
Report of Discrepancy (ROD)	SF 364
Recommended Changes to Equipment Technical Publications	DA Form 2028-2

### A-3. Field Manuals

First Aid for Soldiers	FM 21-11
------------------------	----------

### A-4. Technical Manual

Operator's and Organizational Maintenance Manual, Converter, Direct Current CV-3734/T	TM 11-6130-429-12
Organizational Maintenance Repair Parts and Special Tools List for Converter, Direct Current CV-3734/T	TM 11-6130-429-20P
General Support Maintenance Repair Parts and Special Tools List for Converter Direct Current CV-3734/T	TM 11-6130-429-40P
Administrative Storage of Equipment	TM 740-90-1
Destruction of Army Materiel to Prevent Enemy Use	TM 750-244-2

### A-5. Miscellaneous Publications

Consolidated Index of Army Publications and Blank Forms	DA Pam 310-1
The Army Maintenance Management System (TAMMS)	DA Pam 738-750
Painting and Preservation Supplies Available for Field Use for Electronics Command Equipment	SB 11-573
Preservation, Packaging, Packing and Marking Materials, Supplies and Equipment Used by the Army	SB 38-100
Field Instructions for Painting and Preserving Electronic Command Equipment Including Camouflage Pattern Painting of Electrical Equipment Shelters	TB 43-0118



# APPENDIX B

## EXPENDABLE SUPPLIES AND MATERIALS LIST

---

### Section I. INTRODUCTION

#### **B-1. Scope**

The appendix lists expendable supplies and materials you will need to operate and maintain the CV-3734/T. These are authorized to you by CTA 50-970, Expendable Items (Except Medical, Class V, Repair Parts, and Heraldic Items).

#### **B-2. Explanation of Columns**

*a. Column 1 - Item Number.* This number is assigned to the entry in the listing and is referenced in the narrative instructions to identify the material (e.g., "Use soft bristled brush, item 1, appx B").

*b. Column 2 - Level.* This column identifies the lowest level of maintenance that requires the listed item.

O-Organizational  
H-General Support

*c. Column 3 - National Stock Number.* This is the national stock number assigned to the item. Use it to request or requisition the item.

*d. Column 4 - Description.* Indicates the Federal item name and, if required, a description to identify the item. The last line for each item indicates the part number followed by the Federal Supply Code for Manufacturer (FSCM) in parentheses, if applicable.

*e. Column 5 - Unit of Measure (U/M).* Indicates the measure used in performing the actual maintenance function. This measure is expressed by a two-character alphabetical abbreviation (e.g., ea, in, pr.). If the unit of measure differs from the unit of issue, requisition the lowest unit of issue that will satisfy your requirements.

SECTION II EXPENDABLE SUPPLIES AND MATERIALS LIST

(1) EM NO.	(2) LEVEL	(3) NATIONAL STOCK NUMBER	(4) DESCRIPTION  PART NO. AND FSCM	(5) UNIT OF MEAS
1	0	8020-00-205-6512	BRUSH, PAINT	EA
2	0	8020-00-245-4509	BRUSH, SOFT BRISTLED (CAMELS HAIR)	EA
3	H		COATING, PROTECTIVE	PT
4	0		CLOTH, ABRASIVE	SH
5	0	8305-00-222-2423	CLOTH, LINT-FREE	YD
6	0	7930-00-395-9542	COMPOUND, CLEANING	OT
7	H		COMPOUND, STAKING (GLYPTAL)	PT
8	H		COMPOUND, THERMAL #120-8 WAKEFIELD	OZ
9	0		PAINT, SEMIGLOSS ENAMEL, GRAY #25022, PER MI L-F-14072	QT
10	0	5350-00-598-5905	SANDPAPER NO. 000	SH
11	H		SOLDER, TIN ALLOY, SN60WRMAP2 PER QQ-S-571, FINISH NO. E513	

## APPENDIX C

### ILLUSTRATED LIST OF MANUFACTURED ITEMS

---

**C-1.** This appendix includes instructions for making items authorized to be manufactured or fabricated at general support maintenance.

**C-2.** All parts and bulk materials needed for manu-

facture of the items are listed by part number or specification number in a tabular list on the illustration. Refer to the appropriate figure to fabricate the items.

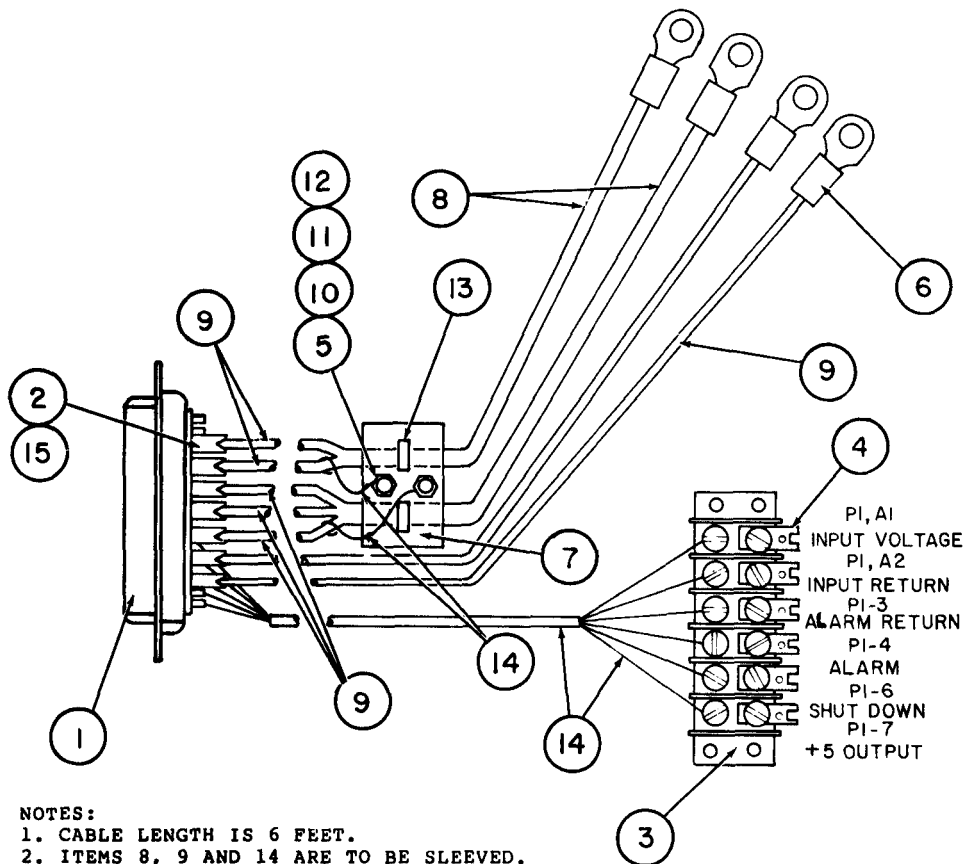

- NOTES:  
 1. CABLE LENGTH IS 6 FEET.  
 2. ITEMS 8, 9 AND 14 ARE TO BE SLEEVED.  
 3. ITEM 5 IS TO BE USED AS TEST POINT.  
 4. SOLDER PER MIL-STD-454, REQUIREMENT 5.

ITEM NO.	NOMENCLATURE OR DESCRIPTION	PART NO. OR IDENTIFYING NO.	QTY REQD
1	CONNECTOR HOUSING	DDMM24W7S (ITT)	1
2	CONNECTOR POWER PINS	DDN53744-21 (ITT)	6
3	TERMINAL BLOCK	600-6 (KULKA)	1
4	TERMINAL LUGS	411 3/4ST (KULKA)	6
5	TERMINAL STANDOFF	28180 (TDI)	2
6	LUG	MS25036-121	4
7	MOUNTING PLATE	32385	1
8	WIRE, UNINSULATED ROPE	AWG 7	AR
9	WIRE, UNINSULATED ROPE	AWG 10	AR
10	WASHER, FLAT, NO. 4	MS15795-804	2
11	WASHER, LOCK NO. 4	MS35338-135	2
12	SCREW PAN HD4-40x3/16	MS51957-12	2
13	CABLE TIE	B4025867-1	2
14	WIRE, ELECTRICAL	E20MIL-W-16878/9	AR
15	SOLDER	SW63WRMAP-2	AR
16	WIRE, INSULATED ROPE	AWG 16	AR

EL9AW024

Figure C-1. Test Cable Fabrication Details.

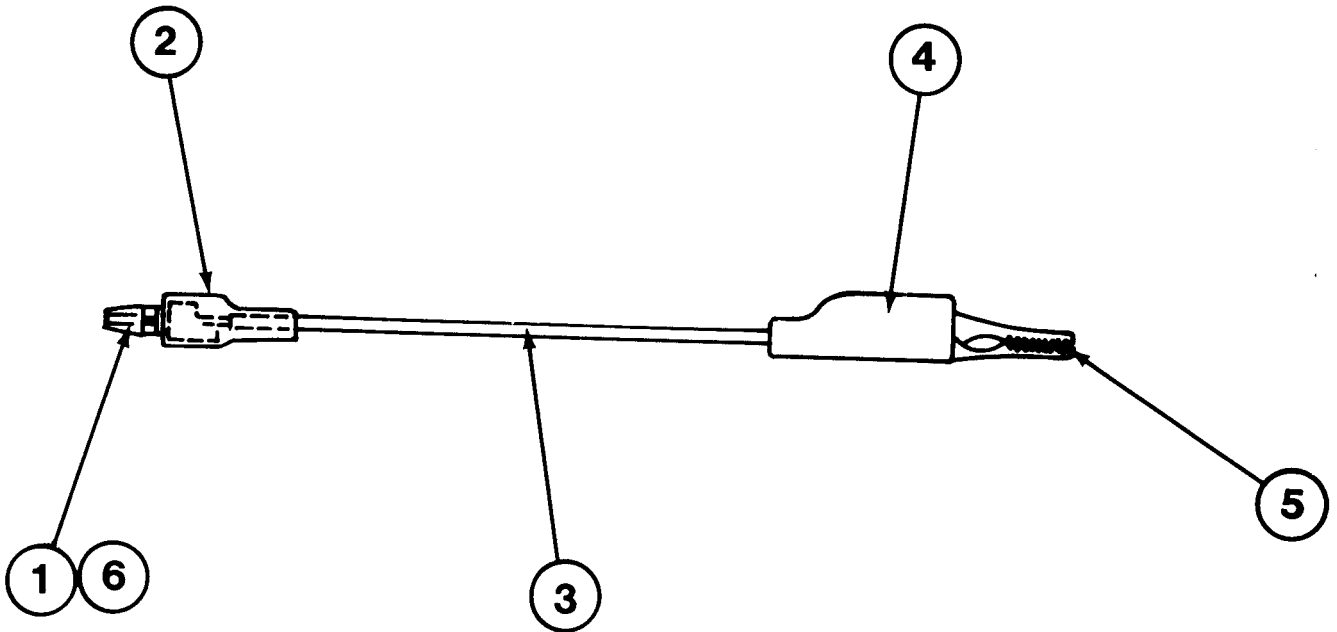

ITEM NO.	CODE IDENT NO.	NOMENCLATURE OR DESCRIPTION	PART NO. OR IDENTIFYING NO.	QTY REQD
1	81348	CONNECTOR POWER PINS	DMS3744-21(ITT)	1
2		SHRINK TUBING (CLEAR)		AR
3		WIRE, ELECTRICAL	E18AWG,MIL-W-168781/9	AR
4		INSULATING BOOT		1
5		ALLIGATOR CLIP (RED)		1
6	81348	SOLDER	SN63WRMAP-2	AR

**EL9AW025**

Figure C-2. Jumper Cable Fabrication Details.





RECOMMENDED CHANGES TO EQUIPMENT TECHNICAL PUBLICATIONS



THEN... JOT DOWN THE DOPE ABOUT IT ON THIS FORM. CAREFULLY TEAR IT OUT. FOLD IT AND DROP IT IN THE MAIL!

SOMETHING WRONG WITH THIS PUBLICATION?

FROM: (PRINT YOUR UNIT'S COMPLETE ADDRESS)  
 Commander  
 Stateside Army Depot  
 ATTN: AMSTA-US  
 Stateside, N.J. 07703-5007

DATE SENT 10 July 1975

PUBLICATION NUMBER  
 TM 11-5840-340-12

PUBLICATION DATE  
 23 Jan 74

PUBLICATION TITLE  
 Radar Set AN/PRC-76

BE EXACT... PIN-POINT WHERE IT IS

PAGE NO	PARA-GRAPH	FIGURE NO	TABLE NO
---------	------------	-----------	----------

2-25	2-28		
------	------	--	--

3-10	3-3		3-1
------	-----	--	-----

5-6	5-8		
-----	-----	--	--

FO3

IN THIS SPACE TELL WHAT IS WRONG AND WHAT SHOULD BE DONE ABOUT IT:

Recommend that the installation antenna alignment procedure be changed throughout to specify a 2° IFF antenna lag rather than 1°.

REASON: Experience has shown that with only a 1° lag, the antenna servo system is too sensitive to wind gusting in excess of 25 knots, and has a tendency to rapidly accelerate and decelerate as it hunts, causing strain to the drive train. Hunting is minimized by adjusting the lag to 2° without degradation of operation.

Item 5, Function column. Change "2 db" to "3db."

REASON: The adjustment procedure for the TRANS POWER FAULT indicator calls for a 3 db (500 watts) adjustment to light the TRANS POWER FAULT indicator.

Add new step f.1 to read, "Replace cover plate removed in step e.1, above."

REASON: To replace the cover plate.

Zone C 3. On J1-2, change "+24 VDC to "+5 VDC."

REASON: This is the output line of the 5 VDC power supply. +24 VDC is the input voltage.

PRINTED NAME, GRADE OR TITLE, AND TELEPHONE NUMBER  
 SSG I. M. DeSpirito 999-1776

SIGN HERE

TEAR ALONG PERFORATED LINE

FILL IN YOUR  
UNIT'S ADDRESS

FOLD BACK

DEPARTMENT OF THE ARMY

\_\_\_\_\_  
\_\_\_\_\_  
\_\_\_\_\_

POSTAGE AND FEES PAID  
DEPARTMENT OF THE ARMY  
DOD 314



OFFICIAL BUSINESS  
PENALTY FOR PRIVATE USE \$300

**SAMPLE**

Commander  
US Army Communications-Electronics Command  
and Fort Monmouth  
ATTN: DRSEL-ME-MP  
Fort Monmouth, New Jersey 07703-5007

TEAR ALONG PERFORATED LINE

RECOMMENDED CHANGES TO EQUIPMENT TECHNICAL PUBLICATIONS



THEN...JOT DOWN THE DOPE ABOUT IT ON THIS FORM. CAREFULLY TEAR IT OUT, FOLD IT AND DROP IT IN THE MAIL.

**SOMETHING WRONG WITH THIS PUBLICATION?**

FROM: (PRINT YOUR UNIT'S COMPLETE ADDRESS)

DATE SENT

PUBLICATION NUMBER

TM 11-6130-429-40

PUBLICATION DATE

14 Jan 1984

PUBLICATION TITLE

Converter, Direct Current  
CV-3734/T

BE EXACT PIN-POINT WHERE IT IS

PAGE NO.

PARA-GRAPH

FIGURE NO.

TABLE NO.

IN THIS SPACE TELL WHAT IS WRONG AND WHAT SHOULD BE DONE ABOUT IT:

TEAR ALONG PERFORATED LINE

PRINTED NAME GRADE OR TITLE AND TELEPHONE NUMBER

SIGN HERE

FILL IN YOUR  
UNIT'S ADDRESS



FOLD BACK

DEPARTMENT OF THE ARMY

\_\_\_\_\_  
\_\_\_\_\_

OFFICIAL BUSINESS  
PENALTY FOR PRIVATE USE \$300

POSTAGE AND FEES PAID  
DEPARTMENT OF THE ARMY  
DOD 314



TEAR ALONG PERFORATED LINE

Commander  
US Army Communications-Electronics Command  
and Fort Monmouth  
ATTN: DRSEL-ME-MP  
Fort Monmouth, New Jersey 07703-5007



FILL IN YOUR  
UNIT'S ADDRESS

FOLD BACK

DEPARTMENT OF THE ARMY

\_\_\_\_\_  
\_\_\_\_\_

OFFICIAL BUSINESS  
PENALTY FOR PRIVATE USE \$300

POSTAGE AND FEES PAID  
DEPARTMENT OF THE ARMY  
DOD 314



TEAR ALONG PERFORATED LINE

Commander  
US Army Communications-Electronics Command  
and Fort Monmouth  
ATTN: DRSEL-ME-MP  
Fort Monmouth, New Jersey 07703-5007

RECOMMENDED CHANGES TO EQUIPMENT TECHNICAL PUBLICATIONS



THEN...JOT DOWN THE DOPE ABOUT IT ON THIS FORM. CAREFULLY TEAR IT OUT, FOLD IT AND DROP IT IN THE MAIL.

**SOMETHING WRONG WITH THIS PUBLICATION?**

FROM: (PRINT YOUR UNIT'S COMPLETE ADDRESS)

DATE SENT

PUBLICATION NUMBER

TM 11-6130-429-40

PUBLICATION DATE

14 Jan 1984

PUBLICATION TITLE

Converter, Direct Current  
CV-3734/T

BE EXACT PIN-POINT WHERE IT IS

PAGE NO.

PARA-GRAPH

FIGURE NO.

TABLE NO.

IN THIS SPACE TELL WHAT IS WRONG AND WHAT SHOULD BE DONE ABOUT IT:

TEAR ALONG PERFORATED LINE

PRINTED NAME GRADE OR TITLE AND TELEPHONE NUMBER

SIGN HERE

FILL IN YOUR  
UNIT'S ADDRESS

FOLD BACK

DEPARTMENT OF THE ARMY

\_\_\_\_\_  
\_\_\_\_\_

OFFICIAL BUSINESS  
PENALTY FOR PRIVATE USE \$300

POSTAGE AND FEES PAID  
DEPARTMENT OF THE ARMY  
DOD 314



TEAR ALONG PERFORATED LINE

Commander  
US Army Communications-Electronics Command  
and Fort Monmouth  
ATTN: DRSEL-ME-MP  
Fort Monmouth, New Jersey 07703-5007



By Order of the Secretary of the Army:

JOHN A. WICKHAM JR.  
*General, United States Army*  
*Chief of Staff*

Official:

DONALD J. DELANDRO  
*Brigadier General, United States Army*  
*The Adjutant General*

DISTRIBUTION:

To be distributed in accordance with DA Form 12-51A-1 literature requirements AN/TTC-38(QTY  
RQR BLK #6902)



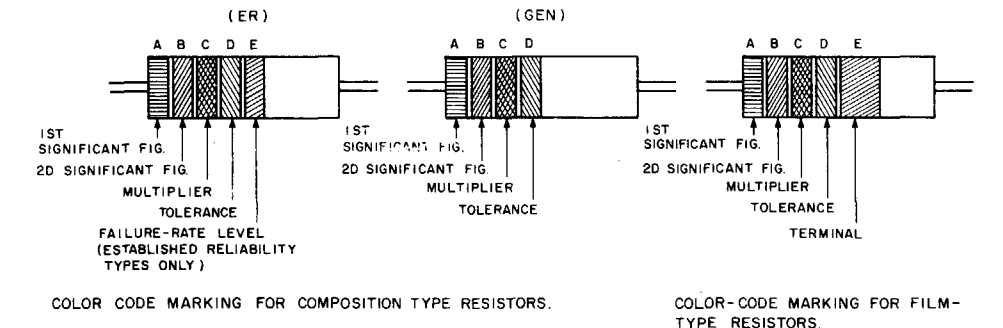

TABLE 1  
COLOR CODE FOR COMPOSITION TYPE AND FILM TYPE RESISTORS.

BAND A		BAND B		BAND C		BAND D		BAND E	
COLOR	FIRST SIGNIFICANT FIGURE	COLOR	SECOND SIGNIFICANT FIGURE	COLOR	MULTIPLIER	COLOR	RESISTANCE TOLERANCE (PERCENT)	COLOR	FAILURE RATE LEVEL
BLACK	0	BLACK	0	BLACK	1	BROWN	±10 (COMP TYPE ONLY)	BROWN	M=1.0
BROWN	1	BROWN	1	RED	10	RED	±2 (NOT APPLICABLE TO ESTABLISHED RELIABILITY)	RED	P=0.1
RED	2	RED	2	ORANGE	100	ORANGE		ORANGE	R=0.01
ORANGE	3	ORANGE	3	YELLOW	1,000	YELLOW		YELLOW	S=0.001
YELLOW	4	YELLOW	4	GREEN	10,000	SILVER		WHITE	
GREEN	5	GREEN	5	BLUE	100,000	GOLD	±5		
BLUE	6	BLUE	6	GRAY	1,000,000	RED			
PURPLE (VIOLET)	7	PURPLE (VIOLET)	7						
GRAY	8	GRAY	8						
WHITE	9	WHITE	9						

BAND A — THE FIRST SIGNIFICANT FIGURE OF THE RESISTANCE VALUE (BANDS A THRU D SHALL BE OF EQUAL WIDTH.)  
 BAND B — THE SECOND SIGNIFICANT FIGURE OF THE RESISTANCE VALUE.  
 BAND C — THE MULTIPLIER (THE MULTIPLIER IS THE FACTOR BY WHICH THE TWO SIGNIFICANT FIGURES ARE MULTIPLIED TO YIELD THE NOMINAL RESISTANCE VALUE.)  
 BAND D — THE RESISTANCE TOLERANCE.  
 BAND E — WHEN USED ON COMPOSITION RESISTORS, BAND E INDICATES ESTABLISHED RELIABILITY FAILURE-RATE LEVEL (PERCENT FAILURE PER 1,000 HOURS). ON FILM RESISTORS, THIS BAND SHALL BE APPROXIMATELY 1/2 TIMES THE WIDTH OF OTHER BANDS, AND INDICATES TYPE OF TERMINAL.

RESISTANCES IDENTIFIED BY NUMBERS AND LETTERS (THESE ARE NOT COLOR CODED)  
 SOME RESISTORS ARE IDENTIFIED BY THREE OR FOUR DIGIT ALPHA NUMERIC DESIGNATORS. THE LETTER R IS USED IN PLACE OF A DECIMAL POINT WHEN FRACTIONAL VALUES OF AN OHM ARE EXPRESSED. FOR EXAMPLE:  
 2R7 = 2.7 OHMS    10R0 = 10.0 OHMS

FOR WIRE-WOUND-TYPE RESISTORS COLOR CODING IS NOT USED. IDENTIFICATION MARKING IS SPECIFIED IN EACH OF THE APPLICABLE SPECIFICATIONS.

EXAMPLES OF COLOR CODING

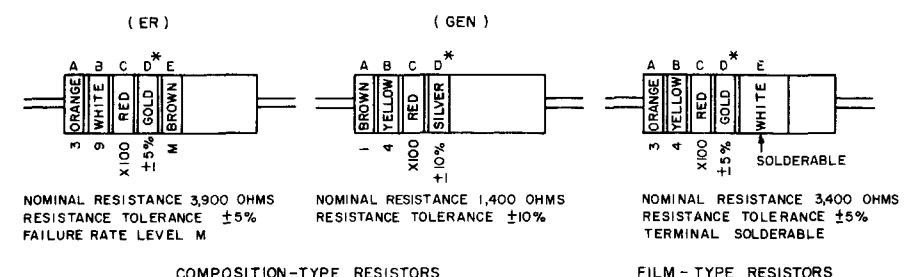

COMPOSITION-TYPE RESISTORS      FILM-TYPE RESISTORS  
 \* IF BAND D IS OMITTED, THE RESISTOR TOLERANCE IS ±20% AND THE RESISTOR IS NOT MIL-STD.

A. COLOR CODE MARKING FOR MILITARY STANDARD RESISTORS.

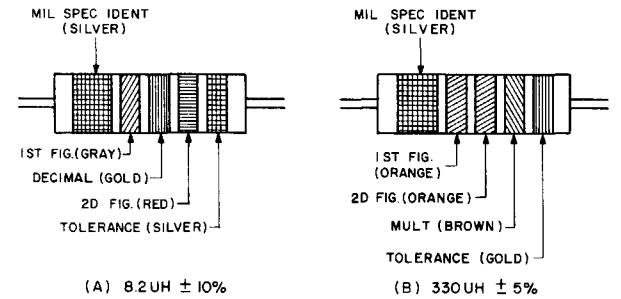

COLOR CODING FOR TUBULAR ENCAPSULATED R.F. CHOKES. AT A, AN EXAMPLE OF THE CODING FOR AN 8.2UH CHOKO IS GIVEN. AT B, THE COLOR BANDS FOR A 330UH INDUCTOR ARE ILLUSTRATED.

TABLE 2  
COLOR CODING FOR TUBULAR ENCAPSULATED R.F. CHOKES.

COLOR	SIGNIFICANT FIGURE	MULTIPLIER	INDUCTANCE TOLERANCE (PERCENT)
BLACK	0	1	
BROWN	1	10	1
RED	2	100	2
ORANGE	3	1,000	3
YELLOW	4		
GREEN	5		
BLUE	6		
VIOLET	7		
GRAY	8		
WHITE	9		
NONE			20
SILVER			10
GOLD			5

MULTIPLIER IS THE FACTOR BY WHICH THE TWO COLOR FIGURES ARE MULTIPLIED TO OBTAIN THE INDUCTANCE VALUE OF THE CHOKO COIL.

B. COLOR CODE MARKING FOR MILITARY STANDARD INDUCTORS.

CAPACITORS, FIXED, VARIOUS-DIELECTRICS, STYLES CM, CN, CY, AND CB.

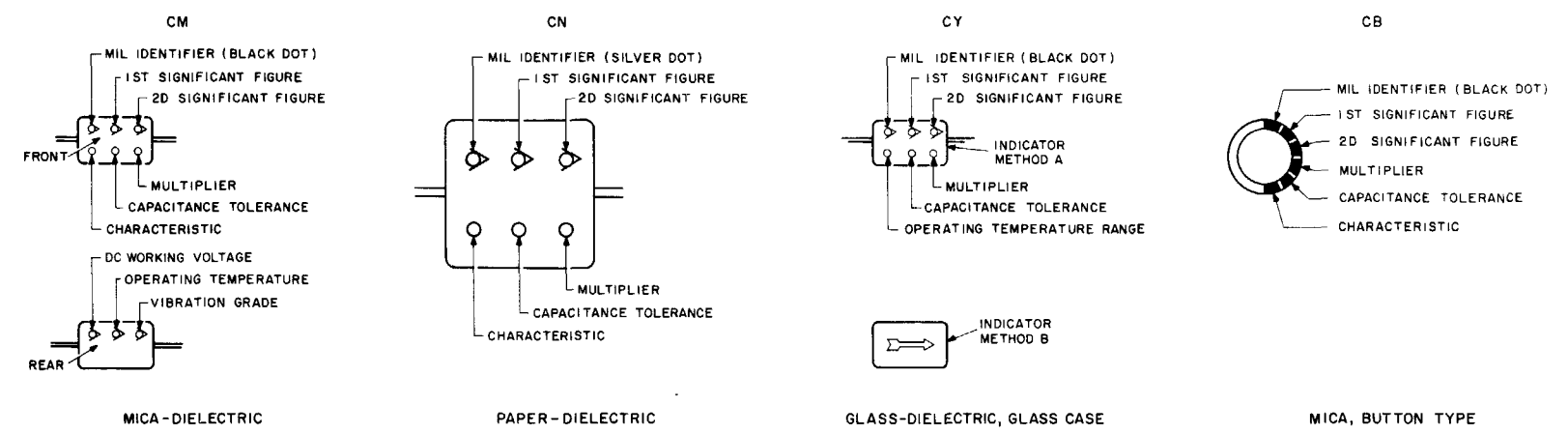

MICA-DIELECTRIC      PAPER-DIELECTRIC      GLASS-DIELECTRIC, GLASS CASE      MICA, BUTTON TYPE

C. COLOR CODE MARKING FOR MILITARY STANDARD CAPACITORS.

TABLE 3 — FOR USE WITH STYLES CM, CN, CY AND CB.

COLOR	MIL ID	1ST SIG FIG	2D SIG FIG	MULTIPLIER	CAPACITANCE TOLERANCE				CHARACTERISTIC			DC WORKING VOLTAGE	OPERATING TEMP. RANGE	VIBRATION GRADE
					CM	CN	CY	CB	CM	CN	CB			
BLACK	CM, CY, CB	0	0	1			±20%	±20%		B	E	B	-55° TO +70°C	10-55 HZ
BROWN		1	1	10										
RED		2	2	100	±2%		±2%	±2%	C		D	D	300	
ORANGE		3	3	1,000		±30%								
YELLOW		4	4	10,000						E			-55° TO +125°C	10-2,000HZ
GREEN		5	5		±5%					F			500	
BLUE		6	6											-55° TO +150°C
PURPLE (VIOLET)		7	7											
GRAY		8	8											
WHITE		9	9											
GOLD				0.1			±5%	±5%						
SILVER	CN			0.01	±10%	±10%	±10%	±10%						

TABLE 4 — TEMPERATURE COMPENSATING, STYLE CC.

COLOR	TEMPERATURE COEFFICIENT*	1ST SIG FIG	2D SIG FIG	MULTIPLIER	CAPACITANCE TOLERANCE		MIL ID
					CAPACITANCES OVER 10 UUF	CAPACITANCES 10 UUF OR LESS	
BLACK	0	0	0	1		±2.0 UUF	CC
BROWN	-30	1	1	10	±1%		
RED	-80	2	2	100	±2%	±0.25 UUF	
ORANGE	-150	3	3	1,000			
YELLOW	-220	4	4				
GREEN	-330	5	5		±5%	±0.5 UUF	
BLUE	-470	6	6				
PURPLE (VIOLET)	-750	7	7				
GRAY		8	8	0.01*			
WHITE		9	9	0.1*	±10%		
GOLD	+100			0.1		±1.0 UUF	
SILVER				0.01			

1. THE MULTIPLIER IS THE NUMBER BY WHICH THE TWO SIGNIFICANT (SIG) FIGURES ARE MULTIPLIED TO OBTAIN THE CAPACITANCE IN UUF.  
 2. LETTERS INDICATE THE CHARACTERISTICS DESIGNATED IN APPLICABLE SPECIFICATIONS: MIL-C-5, MIL-C-25D, MIL-C-11272B, AND MIL-C-10950C RESPECTIVELY.  
 3. LETTERS INDICATE THE TEMPERATURE RANGE AND VOLTAGE-TEMPERATURE LIMITS DESIGNATED IN MIL-C-11015D.  
 4. TEMPERATURE COEFFICIENT IN PARTS PER MILLION PER DEGREE CENTIGRADE.  
 \* OPTIONAL CODING WHERE METALLIC PIGMENTS ARE UNDESIRABLE.

Figure FO-1. Color Code Marking for MIL-STD Resistors, Inductors, and Capacitors.

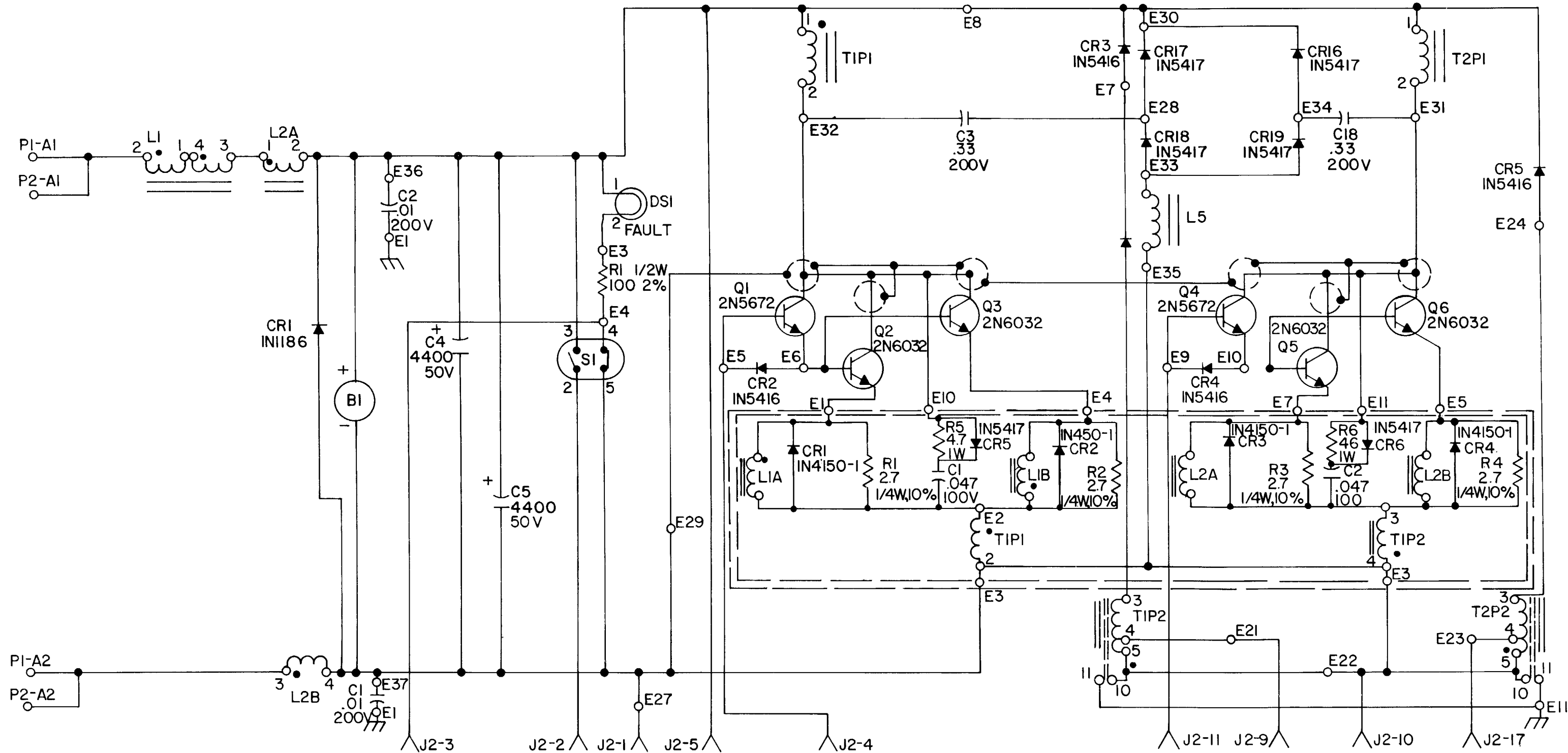

NOTES:  
 1. UNLESS OTHERWISE SPECIFIED:  
 RESISTANCE VALUES ARE IN OHMS, 1/4 W, 2%  
 CAPACITANCE VALUES ARE IN MICROFARADS  
 2. PARTIAL REFERENCE DESIGNATIONS ARE AS  
 SHOWN: FOR COMPLETE DESIGNATION, PREFIX  
 WITH UNIT NUMBER AND SUBASSEMBLY  
 DESIGNATIONS.

**EL9AW027**

Figure FO-2 (1) Converter Assembly Schematic Diagram (Sheet 1 of 4).

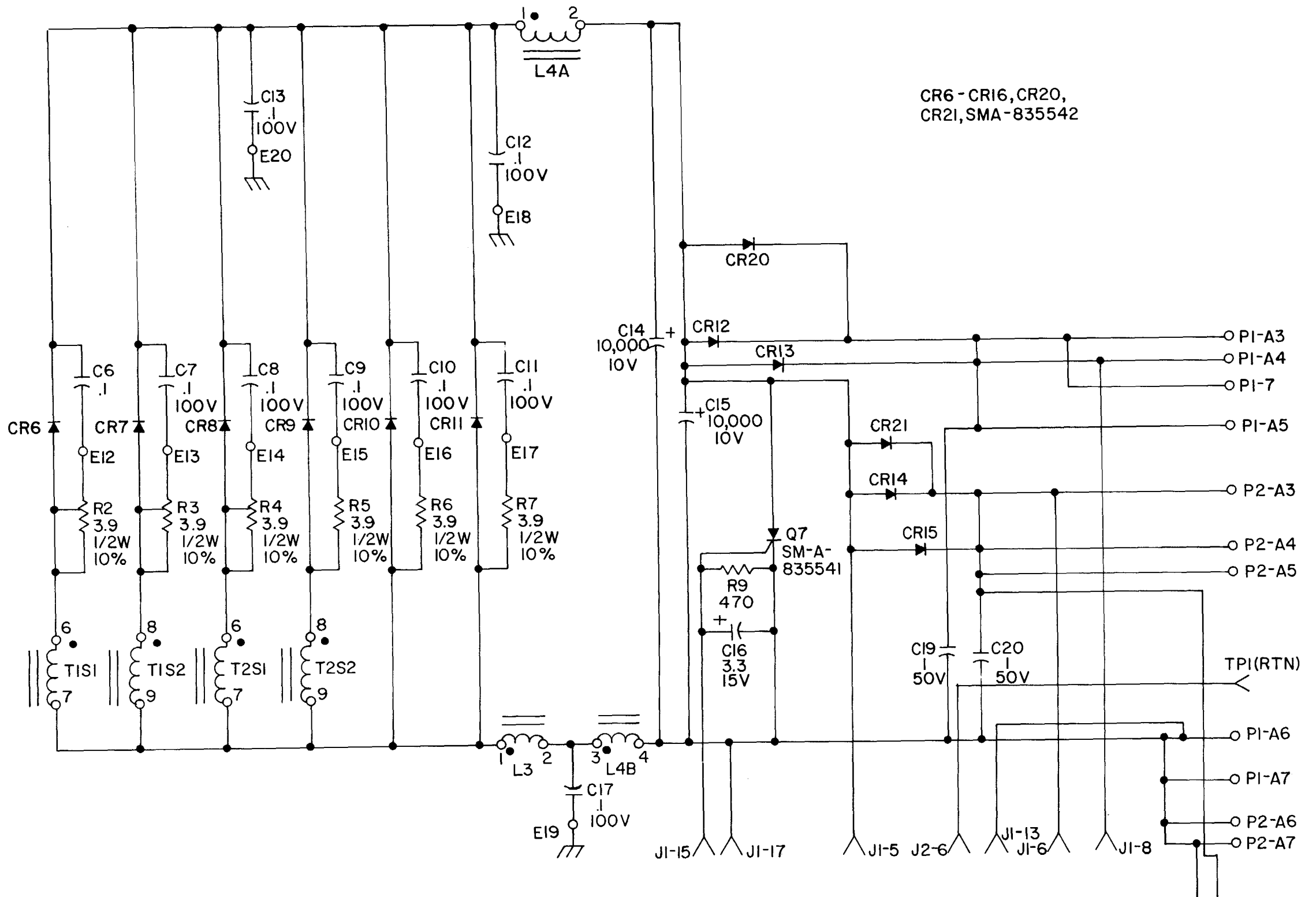

CR6 - CR16, CR20,  
CR21, SMA-835542

**EL9AW028**

Figure FO-2 (2) Converter Assembly Schematic Diagram (Sheet 2 of 4).

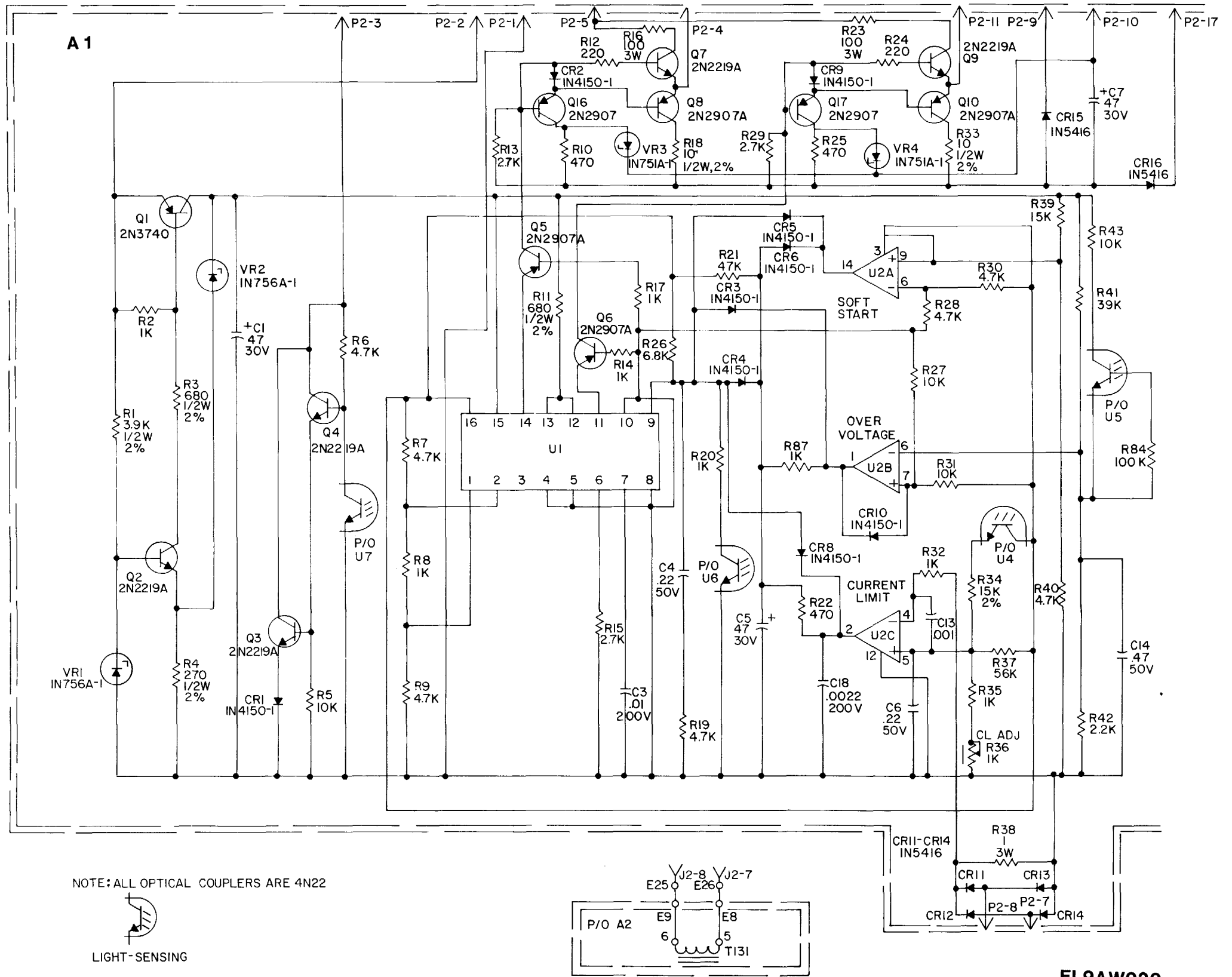

NOTE: ALL OPTICAL COUPLERS ARE 4N22

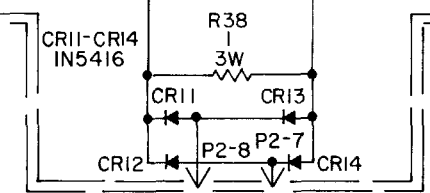
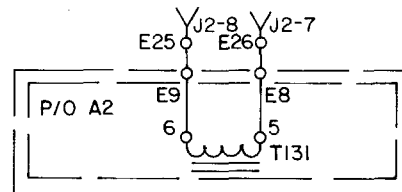

EL9AW029

Figure FO-2 (3) - Converter Assembly Schematic Diagram (Sheet 3 of 4).

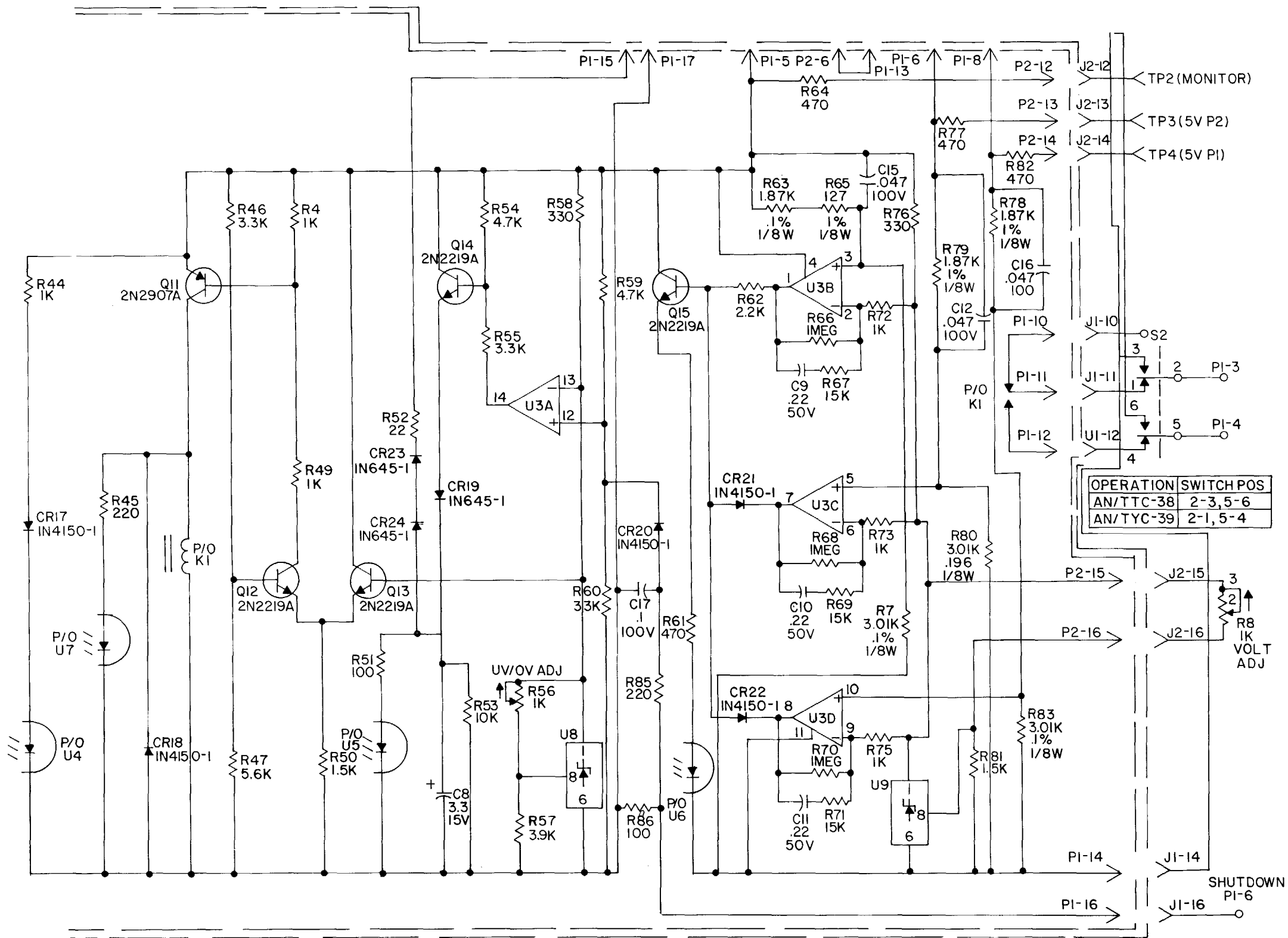

REFERENCE DESIGNATIONS LAST USED															
U9	P2	C20	CR21	R9	Q7	B1	DS1	XDS1	S2	TP4	L5	T2	J2	K1	VR4
		C18	CR24	R87	Q17						L2	T1			
		C2	CR6	R6											
REFERENCE DESIGNATIONS NOT USED															
CR7															

OPERATION SWITCH POS	
AN/TTC-38	2-3, 5-6
AN/TYC-39	2-1, 5-4

NOTE: ALL OPTICAL-COUPPLERS ARE 4N22.



**EL9AW030**

Figure FO-2 (4). Converter Assembly Schematic Diagram (Sheet 4 of 4).